

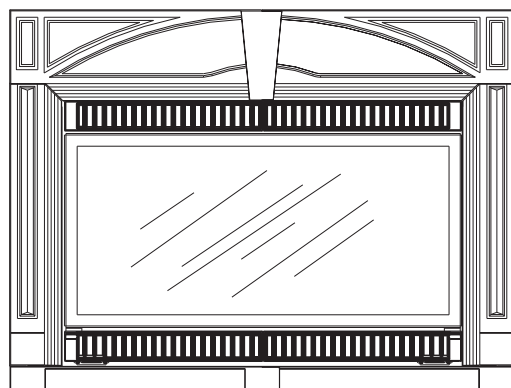

Direct Vent Gas Fireplace Insert

Jøtul GI 450 DV II TSI  
Katahdin



Jøtul TruStart Ignition™

## Installation and Operation Instructions

**WARNING:** If the information in these instructions is not followed exactly, a fire or explosion may result causing property damage, personal injury or loss of life.

- Do not store or use gasoline or other flammable vapors and liquids in the vicinity of this or any other appliance.
  
- **WHAT TO DO IF YOU SMELL GAS**
  - Do not try to light any appliance.
  - Do not touch any electrical switch; do not use any phone in your building.
  - Immediately call your gas supplier from a neighbor's phone. Follow the gas supplier's instructions.
  - If you cannot reach your gas supplier, call the fire department.
- Installation and service must be performed by a qualified installer, service agency or the gas supplier.
- In the Commonwealth of Massachusetts, a carbon monoxide (CO) detector shall be installed in the same room as the appliance.

This appliance may be installed in an aftermarket, permanently located, manufactured home (USA only) or mobile home, where not prohibited by local codes.

This appliance is only for use with the types of gas indicated on the rating plate. A conversion kit is supplied with the appliance.

**ATTENTION :** CES INSTRUCTIONS DOIVENT DEMUERER AVEC LE PROPRIÉTERE D'UNE MAISON.

**AVERTISSEMENT:** Assurez-vous de bien suivre les instructions données dans cette notice pour réduire au minimum le risque d'incendie ou d'explosion ou pour éviter tout dommage matériel, toute blessure ou la mort.

- Ne pas entreposer ni utiliser d'essence ni d'autres vapeurs ou liquides inflammables dans le voisinage de cet appareil ou de tout autre appareil.
  
- **QUE FAIRE SI VOUS SENTEZ UNE ODEUR DE GAZ:**
  - Ne pas tenter d'allumer l'appareil.
  - Ne touchez à aucun interrupteur. Ne pas vous servir des téléphones se trouvant dans le bâtiment où vous trouvez.
  - Appelez immédiatement votre fournisseur de gaz depuis un voisin. Suivez les instructions du fournisseur.
  - Si vous ne pouvez rejoindre le fournisseur de gaz, appelez le service des incendies.
  
- L'installation et l'entretien doivent être assurés par un installateur ou un service d'entretien qualifié ou par le fournisseur de gaz.

**INSTALLER:** Leave this manual with the appliance.

**CONSUMER:** Retain this manual for future reference.



## ! WARNING



**HOT GLASS WILL  
CAUSE BURNS.  
DO NOT TOUCH GLASS  
UNTIL COOLED.  
NEVER ALLOW CHILDREN  
TO TOUCH GLASS.**

## ! AVERTISSEMENT



**Une surface vitrée chaude  
peut causer des brûlures.  
Laisser refroidir la surface vitrée  
avant d'y toucher.  
Ne permettez jamais à un enfant  
de toucher la surface vitrée.**

**THIS OWNER'S MANUAL PROVIDES INFORMATION TO ENSURE SAFE INSTALLATION AND EFFICIENT, DEPENDABLE OPERATION OF YOUR FIREPLACE INSERT. PLEASE READ THESE INSTRUCTIONS IN THEIR ENTIRETY AND MAKE THEM AVAILABLE TO ANYONE USING OR SERVICING THIS GAS INSERT.**

**DO NOT ATTEMPT TO ALTER OR MODIFY THE CONSTRUCTION OF THIS APPLIANCE OR ITS COMPONENTS. ANY MODIFICATION OR ALTERATION WILL VOID THE WARRANTY, CERTIFICATION AND LISTING OF THIS APPLIANCE.**

**THIS HEATER MUST BE INSTALLED AND MAINTAINED BY A QUALIFIED SERVICE AGENCY.**

### Suggested Tools for Installation and Service

- External regulator (for Propane only)
- Piping which complies with local code
- Manual shut-off valve -  
T-Handle required in Massachusetts
- Sediment trap - if required by code
- Tee joint
- Pipe wrench
- Pipe sealant
- 10 mm open end wrench
- 1/2", 7/16" open end wrench
- Phillips head screwdriver
- Flat head screwdriver
- 5/16" and 1/4" nut drivers
- Work Gloves
- Safety glasses
- Torx T-20 screwdriver
- Tin snips

### Installation Requirements for the Commonwealth of Massachusetts

**THIS PRODUCT MUST BE INSTALLED BY A LICENSED MASTER OR JOURNEYMAN PLUMBER OR GAS-FITTER WHEN INSTALLED IN THE COMMONWEALTH OF MASSACHUSETTS.**

1. If there is not one already present, on each floor level where there are bedroom(s), a carbon monoxide detector and alarm shall be placed in the living area outside the bedroom(s). The carbon monoxide detector shall comply with NFPA 720 (2005 Edition).
2. A carbon monoxide detector shall:
  - a) Be located in the room that houses the appliance or equipment;
  - b) Be either hard-wired or battery powered or both; and
  - c) Shall comply with NFPA 720 (2002 Edition).
3. A Product-approved vent terminal must be used, and if applicable, a Product-approved air intake must be used. Installation shall be in strict compliance with the manufacturer's instructions. A copy of the installation instructions must remain with the appliance or equipment at the completion of the installation.

Massachusetts Approval Code G1-0810-45



We recommend that our gas products be installed and serviced by professionals who are certified in the U.S. by the National Fireplace Institute® (NFI) as NFI Gas Specialists.

Canada

**ENERGUIDE**

Gas Fireplace Energy Efficiency Rating

**70.62%**

Based on CSA P.4.1-02

Model No. Jøtul GI 450 DV II TSI



# Table of Contents

<b>Installation &amp; Service Tools</b> .....	2
<b>Unpacking the Fireplace</b> .....	3
<b>Specifications</b> .....	4
<b>General Information</b> .....	5
<b>Safety Information</b> .....	6
<b>Installation</b>	
Fireplace Requirements .....	7
Hearth Protection .....	7
Clearances .....	9
Vent Guidelines.....	10
Masonry Fireplaces .....	11
Prefabricated Fireplaces.....	12
Vent Requirements .....	13
<b>Fireplace Assembly</b>	
Gas Connection.....	14
Gas Pressure.....	14
Fuel Conversion.....	16
High Altitude Adjustment.....	18
Flame Picture Adjustment .....	19
Optional Brick Panel Kits .....	20
Log Set Installation .....	21
Wall Thermostat .....	23
Remote Control .....	23
Surround Assembly.....	24
<b>Operation</b>	
Burner Controls .....	26
Blower Controls .....	27
System Check.....	27
<b>Maintenance</b>	
Annual Cleaning .....	28
Glass Replacement.....	28
<b>Illustrated Part Breakdown</b> .....	30
<b>Appendix A / Wiring Diagram</b> ,.....	32
<b>Appendix B / Simple Surround</b> .....	33
<b>Warranty Statement</b> .....	34
<b>Lighting Instructions</b> .....	35

## Unpacking the Fireplace

1. A Miscellaneous Hardware Kit is packed within the firebox crate. It contains:
  - Installation / Operation manual
  - Fuel Conversion Kit, LP
2. Remove Pallet Bracket screws - two on each side.
3. Remove the Latch Tool and Stabilizer Bar which are screwed to the pallet.
4. Use the Latch Release tool to remove the fireplace glass frame in order to install the log set and other accessories.

Locate the right and left spring latches on the underside of the firebox floor. See fig. 1. Release each latch by engaging the tangs of the tool with the latch release, pulling it down and forward.

Pull the Glass Frame away from the Firebox and lift to disengage it from the retaining lip at the top of the firebox. Set the glass out of the way.

5. The Log Set is packaged separately from the firebox. Do not unpack the log set until you are ready to install it.
6. The Upper and Lower Grill panels and Surround Panels require some assembly. See pages 24-25.

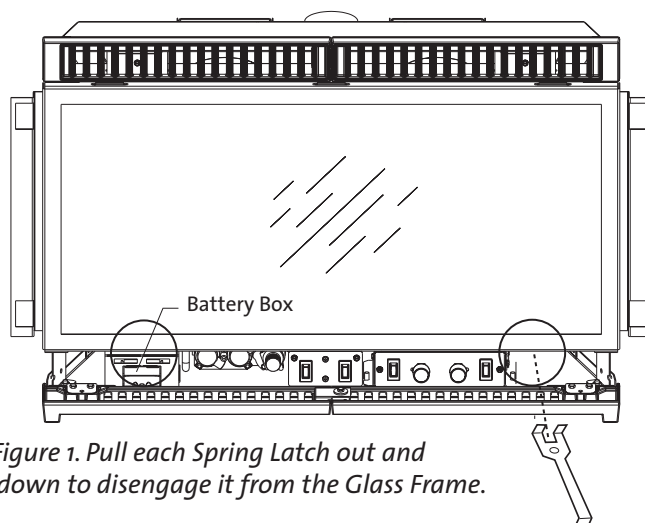

Figure 1. Pull each Spring Latch out and down to disengage it from the Glass Frame.

# Jøtul GI 450 DV II TSI

## Katahdin

### Direct Vent Gas Fireplace Insert



Manufactured and Distributed by:  
 Jøtul North America  
 Gorham, Maine USA

Jøtul AS  
 Fredrikstad, Norway



### Test Standards

This appliance complies with National Safety standards and is tested and listed by Intertek Testing Services of Middleton, Wisconsin.

In addition, the Jøtul GI 450 DV II TSI gas fireplace insert has been tested and listed as a direct vent gas fireplace heater and listed to ANSI Z21.88-2009, ANSI z21.88/CSA 2.33-2009, CAN/CGA 2.17-Mg1, and CSA P.4.-01.2 for Canada.

### Specifications

#### Input Rates

##### Natural Gas

33,000 BTU/hr. maximum input  
 23,750 BTU/hr. minimum input

##### Propane

33,000 BTU/hr. maximum input  
 21,000 BTU/hr. minimum input

Inlet Pressure:	MIN.	MAX.
Natural Gas:	5.0 WC (1.24 kPa)	7.0 WC (1.74 kPa)
Propane:	12.0 WC (2.98 kPa)	16.0 WC (3.98 kPa)

Manifold Pressure:	MIN	MAX.
Natural Gas:	1.6 WC (0.29 kPa)	3.5 WC (0.95 kPa)
Propane:	5.3 WC (0.72 kPa)	11.0 WC (2.74 kPa)

Steady State Efficiency: 75.37%

A.F.U.E. Efficiency: 67.12% ( without pilot )

CSA P4.1-02 Fireplace Efficiency: 70.62%

Electronic Ignition (IPI) or Continuous Pilot (CPI)

**THIS APPLIANCE IS SHIPPED TO USE NATURAL GAS ONLY. FOR USE WITH PROPANE , INSTALL PROPANE CONVERSION KIT #157249, INCLUDED WITH THIS APPLIANCE.**

### Options

- Boston Buff Beige Brick Panel Kit..... #157220
- Chimney Red Brick Panel Kit..... #157221
- Fuel Conversion Kit - NG to LP..... #157249
- Fuel Conversion Kit - LP to NG..... #157250
- High Altitude Adjustment Kit - LP..... #157251
- High Altitude Adjustment Kit- NG..... #157252
- Wall Thermostat ..... #750003
- Remote Control ..... #129706
- Extension Power Cord, 10 ft. .... #223253
- Simple Surround Panel - 40" x 30" ..... #157224
- Cast Iron Surround, Matte Black ..... #350863
- Cast Iron Surround, Blue Back ..... #350864
- Wide Surround Panel\* - 47 3/4" x 34" Matte Black... #157213
- Trimmable Surround Backing Plate - 40" x 30" #157328

\* Custom sizes available. See your dealer for details.

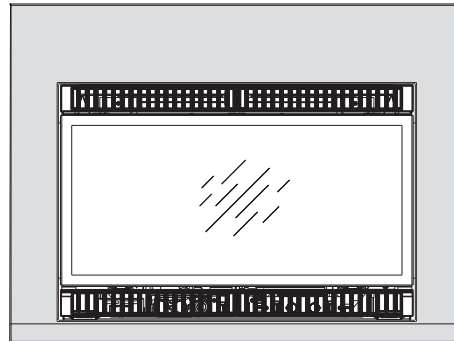

Simple Surround Assembly

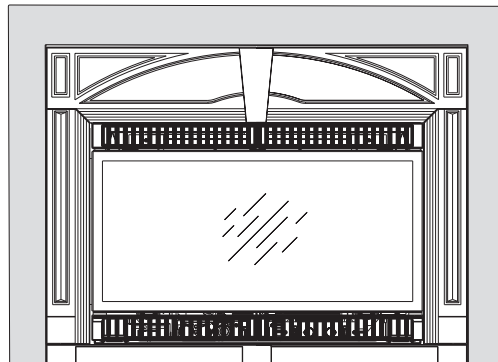

Wide Surround Assembly

# General Information

**THIS HEATER MUST BE INSTALLED AND MAINTAINED BY A QUALIFIED SERVICE AGENCY. DO NOT ATTEMPT TO ALTER OR MODIFY THE CONSTRUCTION OF THIS APPLIANCE OR ITS COMPONENTS. ANY MODIFICATION OR ALTERATION WILL VOID THE WARRANTY, CERTIFICATION AND LISTING OF THIS APPLIANCE.**

## IMPORTANT: SAVE THESE INSTRUCTIONS.

1. The installation and repair of this appliance must be done by a qualified service person. Failure to properly install and maintain this heater could result in an unsafe or hazardous installation, which may result in a fire, explosion, property damage, personal injury or loss of life.
2. This appliance should be inspected before use and at least annually. More frequent cleaning may be required due to excessive lint from carpeting, bedding material, etc. It is imperative that control compartments, burners and circulating air passageways of the appliance be kept clean.

`S'assurer que le bruleur et le compartiment des commandes sont propres. Voir les instructions d'installation et d'utilisation qui accompagnent l'appareil.

3. This appliance may be installed in an aftermarket permanently located, manufactured (mobile) home, where not prohibited by local codes.  
This appliance is only for use with the type(s) of gas indicated on the rating plate. This appliance is not convertible for use with other gases, unless a certified kit is used.

Cet appareil peut être installé dans un maison préfabriquée (mobile) déjà installée à demeure si les règlements locaux le permettent.

Cet appareil doit être utilisé uniquement avec les types de gas indiqués sur la plaque signalétique. Ne pas l'utiliser avec d'autres gas sauf si un kit de conversion certifié est installé.

4. The installation must conform to local codes. Your local Jøtul authorized dealer can assist you in determining what is required in your area for a safe and legal installation. Some areas require a permit to install a gas burning appliance. Always consult your local building inspector or authority having jurisdiction to determine what regulations apply in your area.

In the absence of local codes, the installation requirements must comply with the current National codes. In the U.S., these requirements are established in the National Fuel Code, ANSI Z223.1.(NFPA 54). In Canada, the codes have been established in CAN/CGA B149 Fuel Installation Code.

Installer l'appareil selon les codes ou règlements locaux, ou, en l'absence de tels règlements, selon les Codes d'installation CAN/CGA-B149.

5. Do not operate this fireplace if any part of it has been under water.  
Immediately call a qualified service technician to inspect the heater and to replace any part of the control system and any gas control which has been under water.  
Ne pas se servir de cet appareil s'il a été plongé dans l'eau, complètement ou en partie. Appeler un technicien qualifié pour inspecter l'appareil et remplacer toute partie du système de contrôle et toute commande qui ont été plongés dans l'eau.
6. Do not operate the fireplace with the glass front removed, cracked or broken. Replacement of the glass should be done by a licensed or qualified service person. Only remove glass for routine service. Always handle glass carefully.  
Pour utilisation avec les portes en verre certifiées avec l'appareil seulement ou. Ne pas utiliser avec des portes en verre.
7. Notify your insurance company before proceeding with installation of this fireplace.

Your fireplace insert has a unique serial number stamped on the rating plate which is located in the valve compartment. Please record the serial number in the space below. You may also wish to attach your purchase receipt to this page for future reference.

MODEL NAME: Jøtul GI 450 DV II TSI Katahdin Gas Fireplace

SERIAL NUMBER: \_\_\_\_\_

DATE OF PURCHASE: \_\_\_\_\_

AUTHORIZED DEALER: \_\_\_\_\_

ADDRESS \_\_\_\_\_

PHONE: \_\_\_\_\_

INSTALLER: \_\_\_\_\_

FUEL TYPE: \_\_\_\_\_

FUEL CONVERSION: NO \_\_\_\_\_ YES \_\_\_\_\_

NOTES: \_\_\_\_\_

\_\_\_\_\_

\_\_\_\_\_

# Safety Information

- Due to the high operating temperatures this appliance should be located out of traffic and away from furniture, draperies, etc. Maintain proper clearance to combustible mantels and fireplace trim.
- Children and adults should be alerted to the hazards of high surface temperatures and should stay away to avoid burns or clothing ignition.
- Enfants et adultes doivent être avertis des dangers des températures de surface élevées et devraient rester à l'écart pour éviter les brûlures ou l'inflammation des vêtements.
- Young children should be supervised while they are in the same room as the appliance. Toddlers, young children and others may be susceptible to accidental contact burns. A physical barrier, such as a child guard, is recommended to be used if there are at-risk individuals in the house. To restrict access to a fireplace or stove, install an adjustable safety gate to keep toddlers, young children and other at-risk individuals out of the room and away from hot surfaces.
- Les jeunes enfants doivent être surveillés pendant qu'ils sont dans la même pièce que l'appareil. Les tout-petits, les jeunes enfants et d'autres peuvent être sensibles aux brûlures par contact accidentel. Une barrière physique, comme un garde de l'enfant, est recommandé pour être utilisé si il ya des personnes à risque dans la maison. Pour restreindre l'accès à une cheminée ou un poêle, installer une barrière de sécurité réglable pour garder les tout-petits, les jeunes enfants et autres personnes à risque à se sortir de la salle et à l'écart des surfaces chaudes.
- Any safety screen or guard removed for servicing an appliance must be replaced prior to operating the appliance.
- Tout écran ou grille de protection pour l'entretien d'un appareil doit être remplacé avant de faire fonctionner l'appareil.
- Clothing or other flammable materials should not be placed on or near the fireplace.
- Surveiller les enfants. Garder les vêtements, les meubles, l'essence ou autres liquides à vapeur inflammables loin de l'appareil.
- Never allow anyone to use the fireplace if they are unfamiliar with its operation.
- NEVER store or use gasoline or any other flammable vapors or liquids in the vicinity of the fireplace.
- Never burn any solid materials (wood, cardboard, paper, coal, etc.) in this gas fireplace. Use with natural gas or propane fuel ONLY.

- Do not slam or strike the glass panel.
- This appliance is NOT for use with aftermarket glass doors. This appliance is approved for use only with the surround panel options listed on page 4 of this manual.

Cet appareil ne sert pas avec des portes en verre de marché des accessoires. Cet appareil est approuvé pour l'usage seulement avec les revêtements de porte, entoure les options de panneau et en verre de panneau énumérées à la page 4 de ce manuel.

- Wear gloves and safety glasses while installing or performing maintenance procedures on this appliance.
- This fireplace insert is specifically designed for use with 3" Type B vent pipe components or a Listed flexible or rigid gas liner.

## Electrical Hazards

- Be aware of electrical wiring locations when cutting holes in walls and ceilings for termination.
- The blower must be electrically grounded in accordance with local codes or, in the absence of local codes, with the current ANSI/NFPA 70, National Electrical Code or CSA C22.1-Canadian Electrical Code.
- The Blower is supplied with a three-prong (grounding) plug for protection against shock hazard and should be plugged directly into a properly grounded three-prong receptacle. **DO NOT CUT OR REMOVE THE GROUNDING PRONG FROM THE PLUG.**
- Always disconnect the power supply when performing routine service on the fireplace.



**Leg Leveling Bracket Note:**

Two right and left brackets with mounting hardware are factory installed at zero inches rise. The brackets allow the insert to be raised up to 2 1/2" off of the hearth.

Also note that use of the leveling brackets will affect required minimum clearance to combustible top trim and mantle construction. See the figures and tables on pages 8 and 9.

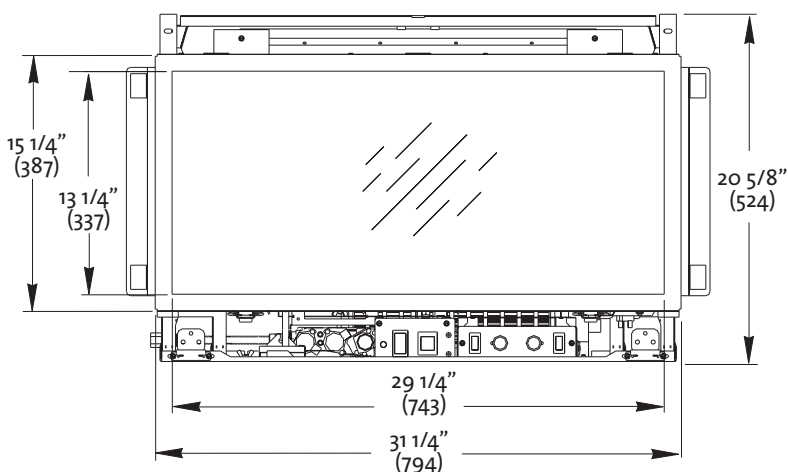
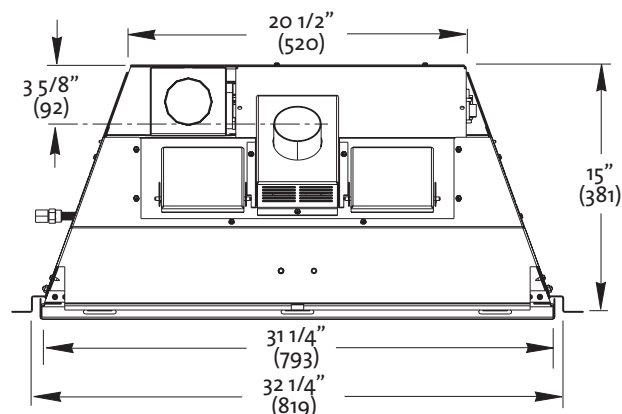
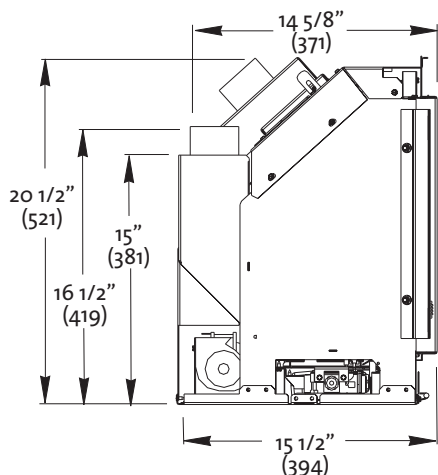

Figure 2. Firebox dimensions.

## Installation Requirements

This insert can be installed in most solid fuel burning fireplaces of either masonry construction or a prefabricated factory built fireplace.

Prior to any installation, the existing chimney exhaust flue must be thoroughly cleaned and completely inspected by a qualified chimney sweep or fireplace service person.

Do not install this insert into a chimney that is damaged. Any repairs must be made prior to installing the insert. If you are unsure of the condition of your fireplace and chimney, contact a professional fireplace technician or your local authorized Jøtul dealer for professional assistance.

**DO NOT REMOVE BRICKS OR MORTAR FROM THE FIREPLACE OR CHIMNEY STRUCTURE.** However, masonry or steel may be removed from the smoke shelf and adjacent damper frame area to accommodate installation of a chimney liner, provided that their removal will not weaken the structure of the fireplace or chimney, and will not reduce protection for combustible materials.

**If the fireplace has been modified to accommodate installation,** use anchors or masonry nails to attach the metal Fireplace Conversion Notice Plate to the back wall of the masonry fireplace firebox where it will be readily seen should the insert be removed.

**THIS APPLIANCE MUST NOT BE CONNECTED TO A CHIMNEY OR FLUE SERVING ANY OTHER APPLIANCE OF ANY KIND.** All venting components must be installed in accordance with the terms of their listing and manufacturer's instructions. Refer to the pipe manufacturer's instructions for proper pipe clearances.

### Power Requirement

This appliance requires 120 V AC power to operate the blower, accent lamps, and electronic ignition system.

Four AA batteries provide back-up power to ignite the pilot in case of a power outage. Keep a supply of extra batteries on hand to ensure uninterrupted use of this appliance.

## Minimum Fireplace Requirements

This fireplace insert has been specifically designed to be installed into a solid fuel burning factory built fireplace or a code approved solid fuel burning masonry fireplace with a tile flue liner. An acceptable fireplace cavity must have the minimum dimensions specified in fig. 3.

**Do not modify or alter the construction of the gas insert or any of its components to enable it to fit into a fireplace. Any modification of the insert will void the warranty, certifications and approvals of the unit and could be dangerous.**

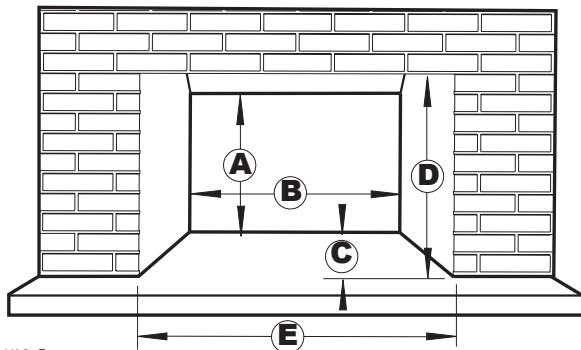

Figure 3.

### Minimum Fireplace Dimensions

- A - Inside Height = 17" (431 mm)
- B - Inside Width = 21" (533 mm)(at 15" of depth)
- C - Inside Depth = 15"
- D - Opening Height = 20 1/2"
- E - Opening Width = 32 1/2"

### Maximum Fireplace Opening

#### Cast Iron Surround or Simple Surround:

Will cover a maximum fireplace opening 27 1/2" high x 39" wide.

The overall Standard Surround dimensions are 28" high X 40" wide.

#### Cast Iron Surround or Simple Surround with 2" Riser Bar:

Will cover a maximum fireplace opening 29 1/2" high x 39" wide

The overall Standard Surround dimensions with the Riser Bar are 30" high X 40" wide.

#### Optional Wide Surround (must be used with Cast Iron Surround):

Will cover a maximum fireplace opening 31 1/2" high X 47" wide.

The overall Wide Surround dimensions are 32" high X 47 5/8" wide.

NOTE: If Wide Surround is used without the Riser Bar, 2" of material must be removed from the bottom leg. See instructions on page 33 for details.

## Clearance Requirements

The following clearances and hearth specifications are the minimum requirements for installing this appliance into a solid fuel-burning fireplace. See figs. 4 - 7.

A combustible surface is anything that can burn (i.e. sheet rock, wallpaper, wood, fabrics etc.). These surfaces are not limited to those that are visible and also include materials that are behind non-combustibles.

If you are not sure of the combustible nature of a material, consult your local fire officials. Remember, "Fire Resistant" materials are considered combustible; they are difficult to ignite, but will burn. Also, "fire-rated" sheet rock is considered combustible.

Always maintain the proper clearances to allow for the flow of ventilation air around the insert.

### Hearth Requirements

Hearth protection in front of the GI 450 DV II TSI must be composed of any noncombustible material extending a minimum 36" wide. Hearth protection must extend a minimum 18" forward of the fireplace glass panel.

**Raised Hearth:** A raised hearth that is at least 6" high requires a non-combustible hearth that extends a minimum 12" from the fireplace glass and is a minimum of 32" wide.

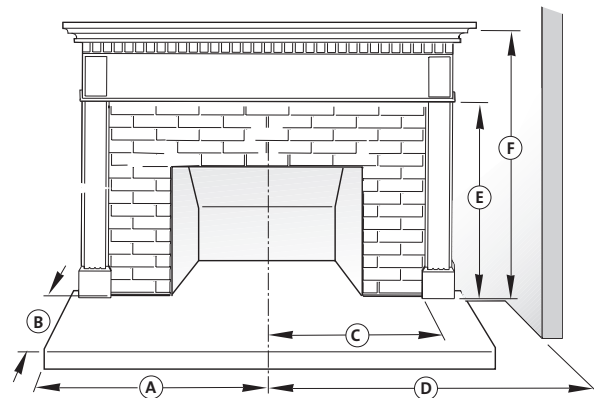

Figure 4. Hearth, Trim and Wall clearances.

#### A: Hearth Protection Width

- Unit flush with hearth: 18"
- Unit raised min. 6" off floor: 16"

#### B: Hearth Protection Depth

- Unit flush with hearth: 18"
- Unit raised min. 6" off floor: 12"

#### C: Side Trim Clearance

- Up to 6" thick, from fireplace center line: 20 1/2"

#### D: Side Room Wall Clearance

- From the fireplace center line: 24 1/2"

#### E: Top Trim Clearance from hearth: 41"

#### F: Mantel Clearance from hearth: See fig. 5



## Mantel and Top Trim Clearances

Measure clearances from the finished floor of the fire-place opening.

- A: 48 1/2" (1232)
- B: 47" (1194)
- C: 45 1/2" (1156)
- D: 44" (1118)
- E: 42 1/2" (1080)
- F: 41" (1041)

**NOTE: THESE CLEARANCES MAY BE REDUCED BY 2" IF THE OPTIONAL RISER BAR IS NOT USED.**

## Leg Leveler Bolts and Brackets

This feature enables greater installation flexibility beyond eliminating problems caused by irregularities in the hearth floor.

The leveling bolts may be extended from the mounting brackets no more than 1/2". See fig. 6.

The firebox may be further raised, in 1/2" increments, up to 2 1/2" more (max. 3" total) by adjusting the height of the leveling bolt mounting brackets as shown in Fig. 7.

## Clearance to Combustibles

When raising the firebox up to 2", mantel and hearth clearances remain unchanged from those specified in fig. 5.

**NOTE: IF RAISING THE UNIT MORE THAN 2 INCHES, ADD 1 INCH TO THE BASELINE CLEARANCES SPECIFIED ABOVE.**

## Stabilizer Bar

In some instances, raising the height of the unit may require installing the insert with the Stabilizer Bar supplied with the insert. See page 24 of this manual for further details.

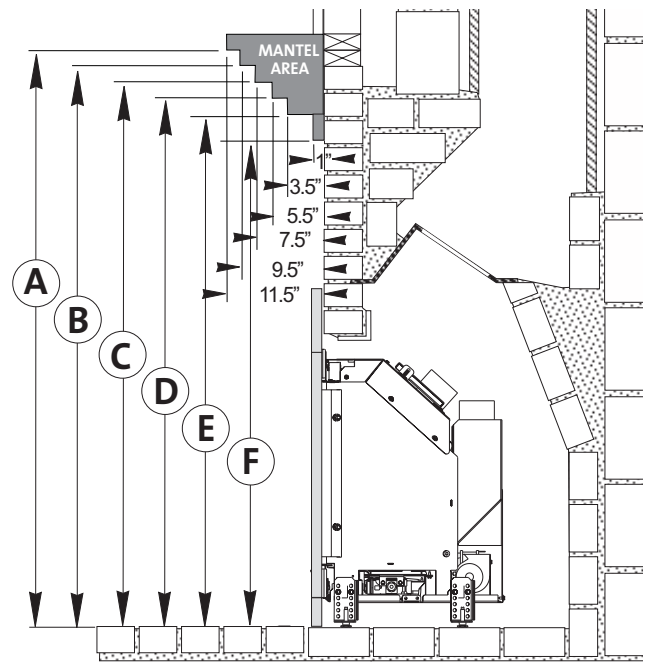

Figure 5. Baseline Mantel and Trim clearance requirements with 2" Riser Bar.

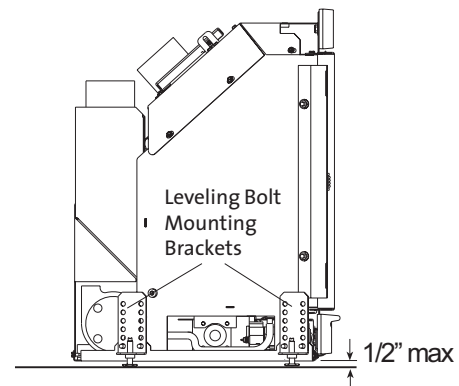

Figure 6. The leveling bolts should not be extended further than 1/2".

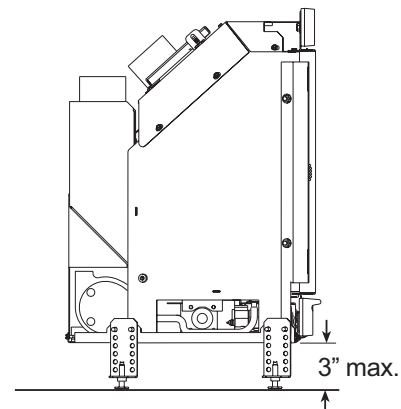

Figure 7. The bolt mounting brackets may be extended up to 2 1/2". With maximum extension of both bolts and brackets, the firebox may be raised a total of 3".

## Vent Guidelines

- All vent components must be installed in accordance with the terms of their listing and manufacturer's instructions.
- The minimum height of termination cap from the top of the unit shall be no less than 10', and the maximum height shall be no more than 40'. See figures 2 and 4.
- Steep roofs, nearby trees, or predominantly windy conditions can promote weak draft or occasional downdrafts. In such cases, increasing the height of the vent or installation of high wind termination caps may alleviate the condition.
- HORIZONTAL RUNS are not permitted anywhere in the venting system.
- Venting liners CANNOT be less than 3" in diameter or greater than 3" in diameter.
- Any unused flue or masonry enclosure can be used as a passageway for venting PROVIDED the flue is relined using 3" Listed Flexible Gas Liner.
- The remaining space around the liner in a masonry or zero-clearance flue CANNOT be used to vent any other appliance.
- Listed Flexible Gas Liners may not be exposed to any living space.
- Installation of any components not manufactured or approved by Jøtul or failure to meet all clearance requirements will void all warranties and could result in property damage, bodily injury, or loss of life.
- Never modify any venting component, or use any damaged venting product.
- THE GAS APPLIANCE AND VENT SYSTEM MUST BE VENTED DIRECTLY TO THE OUTSIDE OF THE BUILDING, AND NEVER ATTACHED TO A CHIMNEY SERVING A SOLID FUEL OR GAS BURNING APPLIANCE.
- The minimum vent height above the roof or adjacent walls is specified by building codes. A general guide to follow is the Gas Vent Rule below.

### GAS VENT RULE

ROOF SLOPE	MINIMUM HEIGHT ABOVE ROOF	
Flat to 6/12	1'0"	0.3M
Over 7/12 to 9/12	2'0"	0.6M
Over 10/12 to 12/12	4'0"	1.2M
Over 13/12 to 16/12	6'0"	1.8M
Over 17/12 to 21/12	8'0"	2.4M

## Vent Installation Procedure

This appliance must be vented through dual 3 inch flexible gas aluminum liners listed for use with gas appliances.

The co-linear installation includes a pair of 3 inch flex ducts that run from the insert up through the existing chimney.

One duct is attached to the exhaust port on the back of the unit and will carry the exhaust gases to the outside of the house. This exhaust liner must run the full length of the chimney and be directly connected to the chimney termination cap. See figure 8.

The other 3 inch liner will be attached to the air intake port on the back of the unit and will provide fresh air for combustion to the unit. This liner must extend a minimum of 6 feet off the back of the unit and extend through the damper area of the fireplace and into the tile liner of the chimney. This liner can also extend the full length of the chimney and connect to the termination cap. See figures 8 and 9.

### IMPORTANT

If the intake flex does not extend the full length of the chimney and connect to the unit and the termination cap - A METAL BLOCK OFF PLATE MUST BE CONSTRUCTED AND INSTALLED ABOVE THE UNIT BELOW THE END OF THE INTAKE DUCT (normally at the damper area). See figure 8.

To avoid cross venting the insert, label the duct to be used for the exhaust conduit at both the top and bottom ends. This ensures that the exhaust duct will be attached to the correct collar on the insert and on the chimney termination kit.

**CANADA NOTE: Both Intake and Exhaust ducts must extend the full length of the chimney and be connected to both the unit and the termination kit.**

### IMPORTANT NOTICE:

**THE USE OF AN EXISTING CHIMNEY AS AN AIR INTAKE IS NOT COVERED UNDER THE ANSI Z21.88-1999-CSA 2.33-M99 TEST METHODS AND RESULTING ITS/WHI PRODUCT CERTIFICATION. THE CODE AUTHORITY HAVING JURISDICTION MUST BE CONSULTED PRIOR TO PROCEEDING WITH THIS INSTALLATION METHOD.**

## Venting through a Masonry Fireplace

1. Measure height of the chimney to fireplace opening. Determine if both the intake and exhaust will be extended to the top of the chimney. In Canada, both liners must extend the full length of the chimney and be connected to both the unit and the termination kit.
2. Cut the appropriate lengths of flex duct for both the intake and exhaust. Label both ends of the Exhaust duct.
3. Follow the manufacturer's instructions to attach the ends of the duct(s) to the chimney termination kit as appropriate.
4. Drop the liners down the chimney from the top and rest the termination kit atop the chimney.
5. Seal the chimney termination kit to the top of the chimney flue with high temperature sealant.
6. Secure the appropriate direct vent cap to the termination kit.
7. Inside the fireplace, fully extend the duct and trim any excess so that the ends hang approximately 15" from the floor of the fireplace.
8. If the Intake duct is not attached to the chimney termination kit:
  - A. Install a length of flex duct that extends at least into the first flue tile.
  - B. The fireplace chimney flue must be permanently sealed-off from the room.
  - C. A direct vent cap is required to allow fresh air into the chimney flue and ultimately into the intake duct to the insert.
9. Compress the ducts so that they are hanging above the height of the fireplace opening and are out of the way.
10. Position the insert without surround panels half-way inside the fireplace and attach duct you labelled Exhaust to the Exhaust collar on the insert. Both Intake and Exhaust collars are labelled.
11. Secure the ducts to the collars with sheet metal screws or hose clamps. No silicone or sealant is required.
12. Once the gas line is installed, carefully push the unit inside the fireplace.

**WARNING: FAILURE TO POSITION THE PARTS IN ACCORDANCE WITH THIS DIAGRAM OR FAILURE TO USE ONLY PARTS SPECIFICALLY APPROVED WITH THIS APPLIANCE MAY RESULT IN PROPERTY DAMAGE OR PERSONAL INJURY.**

**IMPORTANT NOTICE:**  
**INSTALLATION OF A HIGH-WIND TERMINATION CAP IS RECOMMENDED FOR ALL IPI APPLIANCES. IF USING SIMPSON DURA-VENT, AN ADDITIONAL WIND SCREEN #46DVA-VWG IS ALSO RECOMMENDED.**

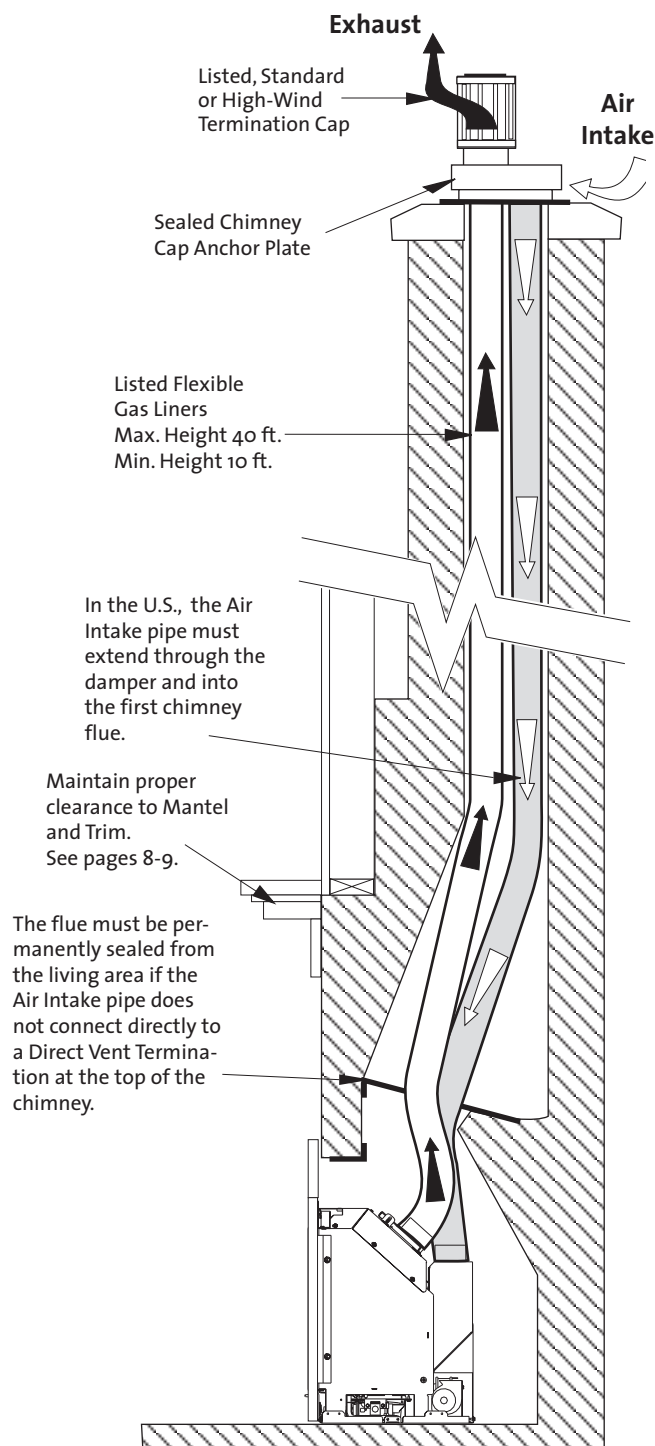

Figure 8. Masonry Fireplace Venting Configuration.  
 CANADA: Air intake must connect to chimney cap.

## Prefabricated Fireplace Installation

### IMPORTANT:

**BEFORE STARTING THIS INSTALLATION, MAKE SURE THAT A GAS LINE CAN BE INSTALLED OR IS INSTALLED TO THE FIREBOX. THIS SHOULD ONLY BE DONE BY A QUALIFIED OR LICENSED PLUMBER OR GAS FITTER.**

A factory-built fireplace will require modification prior to installation of the insert.

### Modification

1. Remove any fuel grate and other components attached to the firebox. Do not cut out any sheet metal parts of the fireplace into which the insert will be installed.
- If the factory-built fireplace has no gas access hole(s) provided, an access hole of 1 1/2" (37.5 mm) or less may be drilled through the lower sides or bottom of the firebox in a proper workmanship-like manner. This access hole must be sealed with non-combustible insulation after the gas supply has been installed.
2. Remove the damper assembly. This includes the damper blade, handle and any linkage. Two 3" liners must be able to pass through the damper area.
3. Remove any firescreen or door assembly. This is usually accomplished with removal of a support rod on the inside of the fireplace frame.
4. Remove the metal ashlip, if appropriate, to allow the insert to sit flat within the fireplace. Be sure to reinstall any screws removed.
5. Attach the fireplace conversion notice to the back of the factory-built fireplace.

### NOTICE:

If the intake flex does not extend the full length of the chimney and connect to the unit and the termination cap - A METAL BLOCK OFF PLATE MUST BE CONSTRUCTED AND INSTALLED ABOVE THE UNIT BELOW THE END OF THE INTAKE DUCT (normally at the damper area). See figure 9.

To avoid cross venting the insert, label the duct to be used for the exhaust conduit at both the top and bottom ends. This ensures that the exhaust duct will be attached to the correct collar on the insert and on the chimney termination kit.

**CANADA NOTE:** Both Intake and Exhaust ducts must extend the full length of the chimney and be connected to both the unit and the termination kit.

**IMPORTANT NOTICE:**  
INSTALLATION OF A HIGH-WIND TERMINATION CAP IS RECOMMENDED FOR ALL IPI APPLIANCES. IF USING SIMPSON DURA-VENT, AN ADDITIONAL WIND SCREEN #46DVA-VWG IS ALSO RECOMMENDED.

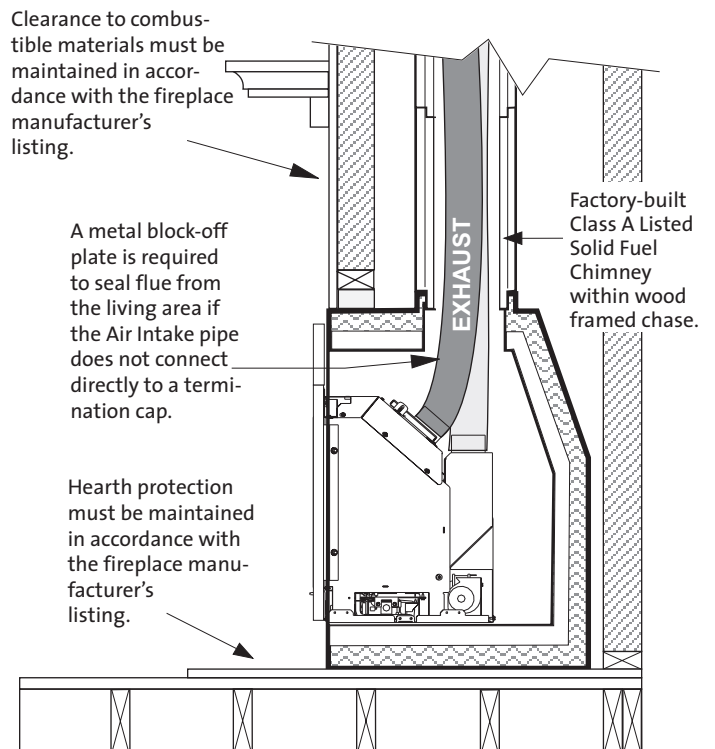
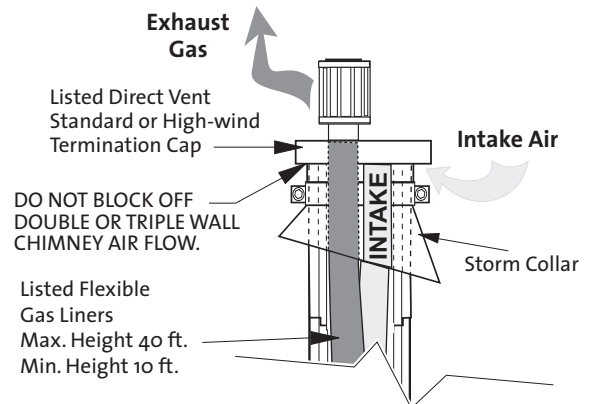

Figure 9. Venting through prefabricated fireplace chimney.

### IMPORTANT NOTICE:

THE USE OF AN EXISTING CHIMNEY AS AN AIR INTAKE IS NOT COVERED UNDER THE ANSI Z21.88-1999-CSA 2.33-M99 TEST METHODS AND RESULTING ITS/WHI PRODUCT CERTIFICATION. THE CODE AUTHORITY HAVING JURISDICTION MUST BE CONSULTED PRIOR TO PROCEEDING WITH THIS INSTALLATION METHOD.

## Prefabricated Fireplace Vent Procedure

1. Measure height of the chimney to fireplace opening. Determine if both the intake and exhaust will be extended to the top of the chimney.
2. Cut the appropriate lengths of flex for both the intake and exhaust.
3. **If the intake flex will be attached to the chimney termination kit:** Attach the appropriate ends of the flex to the chimney termination kit.

CAUTION: AVOID CROSS-VENTING THE FLEX PIPE. Label the end of the exhaust pipe.

4. Drop the liners down the chimney from the top and rest the termination kit atop the chimney.
5. Seal the chimney termination kit to the top of the chimney pipe with high temperature sealant.
6. Secure the appropriate DIRECT VENT CAP to the termination kit.
7. Inside the fireplace, fully extend the flex and cut off the excess flex so that the liners hang approximately 15" from the floor of the fireplace.
8. **If the intake flex is NOT attached to the chimney termination kit:** See NOTICE on page 12.

A. It is necessary to install a minimum 6 foot length of flex pipe into the flue for the intake air.

B. A METAL damper block off plate must be constructed and installed in the damper area to completely seal off the flue from the room. Cut holes for both the intake and exhaust liners in the block off plate.

C. A direct vent cap is still required to allow fresh air into the chimney flue and ultimately into the intake flex and insert.

D. Attach the Fireplace Conversion Notice to the back of the fireplace if appropriate.

9. Surround panels must not block or seal any ventilation openings on the prefabricated fireplace.

**WARNING: FAILURE TO POSITION THE PARTS IN ACCORDANCE WITH THIS DIAGRAM OR FAILURE TO USE ONLY PARTS SPECIFICALLY APPROVED WITH THIS APPLIANCE MAY RESULT IN PROPERTY DAMAGE OR PERSONAL INJURY.**

## Vent Connection

### Wear Safety Gloves!

1. Push the insert partially into the fireplace cavity, leaving access to the duct collars.
2. Identify the end of the Exhaust duct and secure it to the collar on the insert using a clamp.
3. Secure the other duct to the collar labeled AIR INTAKE.

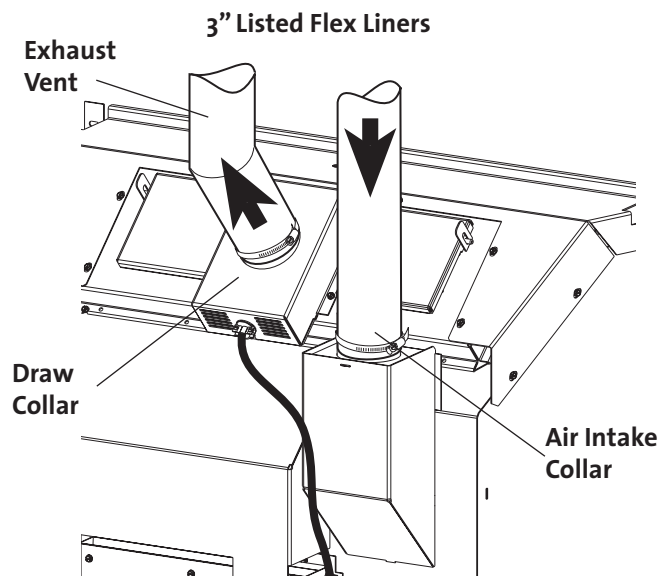

Figure 10. Duct collar locations.

## Final Positioning

### 1. Power Supply:

Extend the unit power cord out forward of the fireplace, routing it to the nearest power source. Measured from the fireplace center line, it can extend up to 5 1/2 feet to the right, and up to 3 1/2 feet to the left.

A 10 foot extension cord is available from your Jøtul dealer, PN 223253.

### 2. Level and Plumb the Cabinet:

With the fireplace cabinet in its final position, confirm that it is level and plumb.

Adjust the leg levelers at each corner as appropriate to fine-tune the level up to 1/2". If a greater height increase is required, the brackets can be lowered in 1/2" increments to raise the cabinet up to 2 1/2".



## Gas Supply Connection

The gas supply line connection is made to the valve on the left side of the unit facing the front. The gas supply line should be a minimum of 3/8" in diameter, or the appropriate size to provide sufficient gas pressure to the valve regardless of the input setting.

See fig. 11 and 12.

For your convenience, the GI 450 DV II TSI Katahdin is shipped with a length of 3/8" cast iron nipple and a 36" length of flexible gas line. Jotul recommends the use of the flexible gas line for ease of installation and service. However, for those areas where flexible gas lines are not permitted, use of the 3/8" iron nipple is recommended. See fig. 11.

The use of Flexible Gas Appliance Connectors is acceptable in many areas in the U.S., however, Canadian methods vary depending on local code.

ALL INSTALLATIONS MUST COMPLY WITH LOCAL CODE OR IN THE ABSENCE OF LOCAL CODE, MUST COMPLY WITH THE MOST RECENT EDITION OF THE NATIONAL FUEL GAS CODE ANSI Z223.1/NFPA 54 OR CAN-B149.

All codes require: a gas shut-off valve (gas cock) .union, to be installed in the supply line, and in the same room as the appliance. This allows for the disconnection of the insert for servicing and maintenance. See fig. 11.

Secure all joints tightly using appropriate tools and sealing compounds (for propane units, be sure to use compounds that are propane resistant). Turn on gas supply and test for gas leaks using a soapy water solution or electronic gas sensor. Never use an open flame to check for leaks. Tighten or reconnect the leaking joint and retest for any gas leaks.

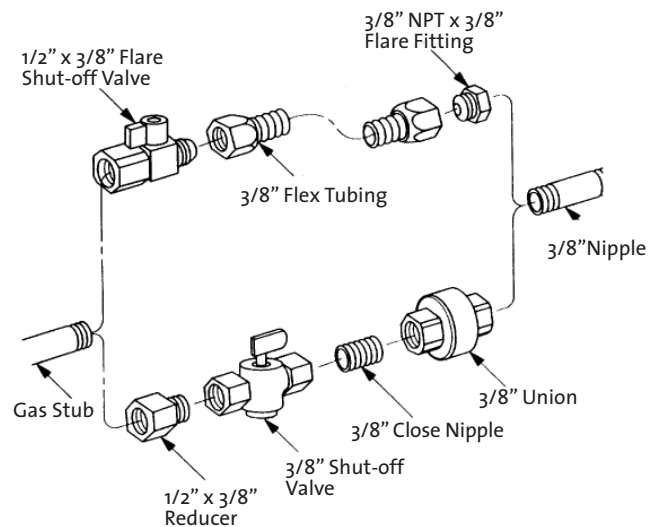

Figure 11. Gas connection components.

**INSTALLATION OF A T-HANDLE GAS COCK IS REQUIRED IN MASSACHUSETTS IN COMPLIANCE WITH CODE 248CMR.**

## Gas Pressures

Correct gas pressure is essential for efficient and safe operation of the Katahdin gas insert. It is important that the correct pressure is established at the time of the installation.

Proper gas pressure provides a consistent flow of gas to the appliance and is instrumental in checking for gas leaks. The gas control valve on the insert is equipped with pressure test points for gauge connections. The gauge connections are located on the front of the valve. See fig. 12.

- **IN** for inlet or supply pressure (the amount of gas coming to the valve.)
- **ptp OUT** for manifold pressure (the amount of gas that is coming out of the valve to the burner.)

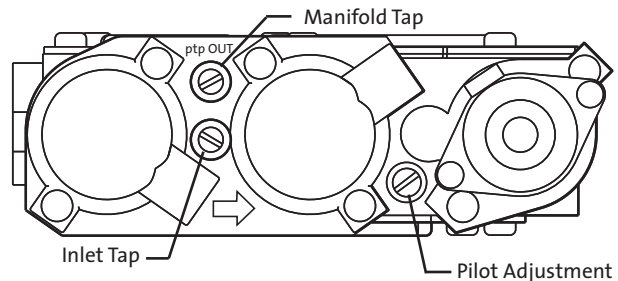

Figure 12. Pressure test and pilot adjustment points.

The appliance must be isolated from the gas supply line by closing its individual manual gas shut-off valve (gas cock) during any pressure testing of the gas supply piping system that is equal to or exceeds pressures of 1/2 psig (3.5kPa).

### NECESSARY INLET GAS PRESSURES (inches water column)

	MIN	MAX
NATURAL GAS	5.0 WC	13.85 WC
PROPANE	12.0 WC	13.85 WC

### NECESSARY MANIFOLD PRESSURES (inches water column)

	MIN	MAX
NATURAL GAS	1.6 WC	3.5 WC
PROPANE	5.3 WC	11.0 WC

**ALWAYS TEST PRESSURE WITH THE VALVE REGULATOR ADJUSTED TO THE HIGHEST SETTING.**



**Symptoms of incorrect gas pressure include:****Insufficient gas pressure:**

- Small pilot flame which can result in poor pilot rectification and/or frequent burner outages.
- Little variation in flame picture between HI and LO regulator settings.
- Insufficient gas to support more than one appliance causing nuisance outages or gas surges.

**Excessive gas pressure:**

- Permanent damage to valve causing complete appliance shut down.
- Too large a pilot flame resulting in overheating of the flame sensor and consequent shut down.
- Sooting due to impingement and/or incorrect fuel to air mix.

**WARNING**

**DO NOT ALLOW THE INLET GAS PRESSURE TO EXCEED 14.0" WC (OR 1/2 PSIG) AS SERIOUS DAMAGE TO THE VALVE MAY RESULT.**

## Fuel Conversion

The Jøtul GI 450 DV II TSI is shipped from the factory equipped to burn Natural gas. Fuel Conversion Kits are available to convert the system to Propane and also back to Natural gas. The kit contains all the necessary components, including labels that must be applied to the insert.

### WARNING:

**THE CONVERSION KIT IS TO BE INSTALLED BY AN AUTHORIZED JØTUL SERVICE TECHNICIAN IN ACCORDANCE WITH THE MANUFACTURER'S INSTRUCTION AND ALL CODES AND REQUIREMENTS OF THE AUTHORITY HAVING JURISDICTION. FAILURE TO FOLLOW THESE INSTRUCTIONS COULD RESULT IN SERIOUS INJURY OR PROPERTY DAMAGE. THE QUALIFIED AGENCY PERFORMING THIS WORK ASSUMES RESPONSIBILITY FOR THIS CONVERSION.**

### IN CANADA:

**THE CONVERSION SHALL BE CARRIED OUT IN ACCORDANCE WITH THE REQUIREMENTS OF THE PROVINCIAL AUTHORITIES HAVING JURISDICTION AND IN ACCORDANCE WITH THE REQUIREMENTS OF THE CAN1-B149.1 AND .2 INSTALLATION CODE.**

**CET EQUIPEMENT DE CONVERSION SERA INSTALLE PAR UNE AGENCE QUALIFIEE DE SERVICE CONFORMEMENT AUX INSTRUCTIONS DU FABRICANT ET TOUTES EXIGENCES ET CODES APPLICABLES DE L'AUTORISES AVOIR LA JURIDICTION. SI L'INFORMATION DANS CETTE INSTRUCTION N'EST PAS SUIVIE EXACTEMENT, UN FEY, EXPLOSION OU PRODUCTION DE PROTOXYDE DE CARBONE PEUT RESULTER BLESSURE PERSONNELLE DE VIE. L'AGENCE QUALIFIEE DE SERVICE EST ESPONSABLE DE L'INSTALLATION N'EST PAS PROPRE ET COMPLETE JUSQU'A L'OPERATION DE L'APPAREIL CONVERTI EST CHEQUE SUIVANT LES CRITERES ETABLIS DANS LES INSTRUCTIONS DE PROPRIETAIRE PROVISIONNEES AVEC L'EQUIPEMENT.**

### Conversion Kit LP #157249 / NG #157250

#### Tools required:

- 1/2" & 13 mm open end wrench or deep-well socket
- Torx T20 driver
- 1/4" nut driver
- 4 mm allen wrench

#### Conversion Kit Contents:

- 1 regulator tower labeled for the appropriate fuel
- 2 regulator tower Torx screws
- 1 burner injector: #33- NG / #52 - LP
- 1 pilot orifice: #62 - NG / #35 - LP
- Label A - to be completed and applied to the base of the valve compartment
- Label B - apply to the rating plate in the space indicated on the plate.
- Small valve label - apply to valve body
- Conversion instructions
- 4 mm hex key

### SIT Proflame 88o Valve

#### Rating Specifications:

	NG	LP
Min. Input Rate, 0 - 2000 ft.	23,750	21,000
Max. Input Rate, 0 - 2000 ft.	33,000	33,000
Max. Input Rate, up to 4500 ft.	31,500	32,000

## Fuel Conversion Procedure

1. Turn off gas supply to the appliance and disconnect from electrical power source.
2. Remove the glass frame. Use the latch release tool, provided with the insert, to release the two latches located on the underside of the firebox floor. Engage the tool with the latch and pull it forward and down to release. See fig. 13.
3. Loosen the Air Shutter stem wing nut, located under the firebox. Slide the shutter stem all the way to the left. See fig. 14.
4. Remove the burner tube. Tilt it forward and pull it up and over to the right to disengage it from the air shutter.

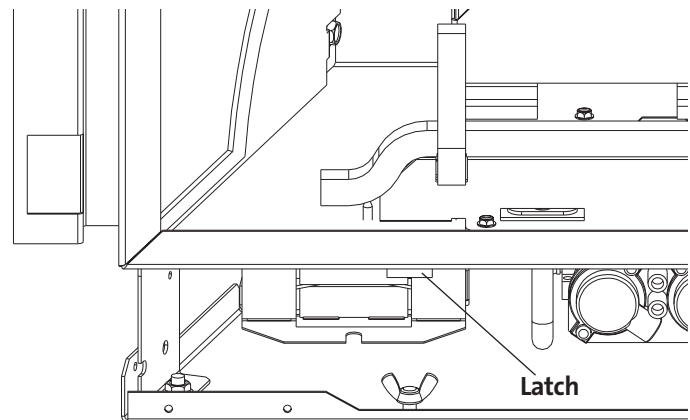

Figure 13. Glass frame latch locations.

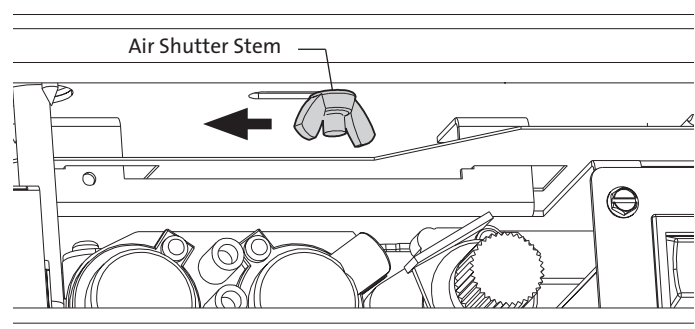
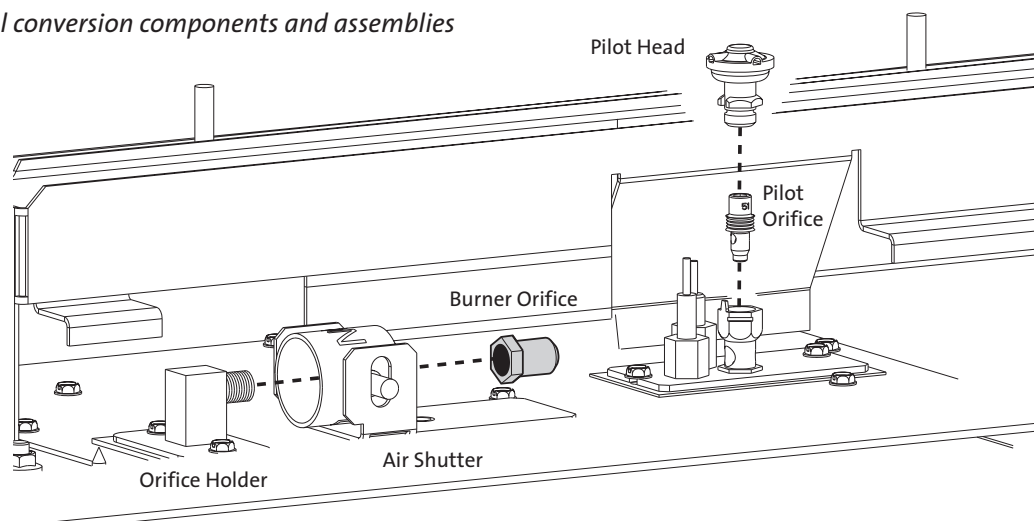

Figure 14. Air Shutter Stem location above valve.

Figure 15. Fuel conversion components and assemblies



5. Use a 1/2" open end wrench or deep-well socket to remove the burner orifice from the brass orifice holder. Replace with the orifice supplied in conversion kit and tighten securely. See fig. 15.
6. Change the Air Shutter position: Lift the shutter tube up in its hinge pin slots and turn the tube over, so that the appropriate fuel type indicator (LP or NG) is oriented facing you. See fig. 16. Push the shutter all the way back over the burner orifice.
7. Change the Pilot Orifice. Pull the Pilot Hood off of its base. It will snap by the retainer clip shown in Fig. 15. Using a 4 mm allen wrench, unscrew the pilot orifice. Replace it with the orifice from the kit. Be sure the new orifice is tightly secured to prevent by-pass leakage.  
Replace the pilot hood. Use a small spade screwdriver to pry back the retainer clip and re-insert the head onto the base.
8. Reinstall the burner tube, engaging it within the air shutter. **BE CERTAIN THE BURNER IS LEVEL AND SECURELY SEATED ON THE FIREBOX FLOOR.** Properly located, it should not be able to move it to the right or left.
9. Replace the variable regulator on the gas control valve. Remove the TruStart switch faceplate and move the assembly out of the way to access the regulator. Using a Torx T-20 screwdriver, remove the two screws from the regulator tower on the front of the valve as shown in fig. 17.
10. Remove the regulator tower and the rubber diaphragm.
11. Install the new regulator tower from the kit. Be sure that the gasket is properly positioned and tighten screws securely.
12. Apply the conversion notice labels to the appliance so that they can be seen by any person that may be servicing the unit.
  - Label "A": Apply to the floor of the valve compartment.
  - Label "B": Apply to the Rating Plate.
  - Small valve sticker: Apply to valve body.

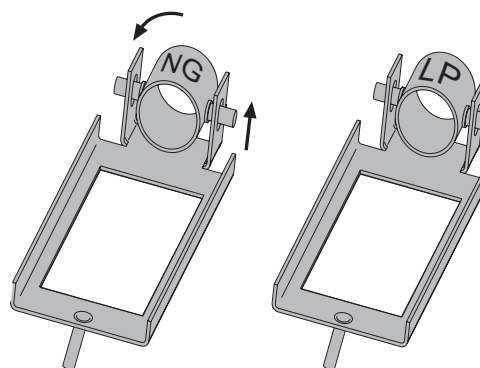

Figure 16. Air Shutter orientation must be changed for fuel type.

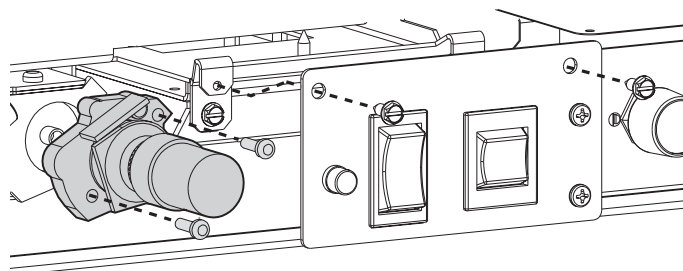

Figure 17. Replacing the regulator.

13. Use an electronic gas detector or soap solution to test for leaks at the pilot head and all gas line joints. **NEVER USE AN OPEN FLAME TO CHECK FOR GAS LEAKS.**
14. **Pressure Test:**  
Conduct a pressure test of the valve following the guidelines on page 14 of this manual.

## High Altitude Adjustment

When installing this appliance at altitude above 2000 feet, it is necessary to compensate for the thinner air (less volume of air per cubic foot). Higher altitudes affect the atmospheric pressure and heat value of gaseous fuels. The lower oxygen content in the air and the lower gas viscosity require the use of a different orifice to achieve efficient, clean combustion at the burner tube.

### In the U.S.

**THE DE-RATING KIT MUST BE INSTALLED BY AN AUTHORIZED SERVICE TECHNICIAN IN ACCORDANCE WITH THE MANUFACTURER'S INSTRUCTIONS AND ALL CODES AND REQUIREMENTS OF THE AUTHORITY HAVING JURISDICTION. THE INFORMATION STICKER MUST BE FILLED OUT BY THE INSTALLER AND APPLIED TO THE APPLIANCE AT THE TIME OF THE CONVERSION. THE QUALIFIED SERVICE AGENCY PERFORMING THIS WORK ASSUMES RESPONSIBILITY FOR THIS DE-RATING.**

### In Canada

**This unit has been tested for installation at high altitudes in accordance with Canadian test standard CAN/CGA-2.17. THE DE-RATING SHALL BE CARRIED OUT IN ACCORDANCE WITH THE REQUIREMENTS OF THE PROVINCIAL AUTHORITIES HAVING JURISDICTION AND IN ACCORDANCE WITH THE REQUIREMENTS OF THE CAN1-B-149.1 AND .2 INSTALLATION CODE.**

### High Altitude Installations:

2000 ft. to 4500 ft. installations (or 610 m - 1370 m)  
See Table 1.

For high altitude installations consult the local gas distributor or the authority having jurisdiction for proper rating methods. If the installer must convert the unit to adjust for varying altitudes, the information label must be completed by the installer and applied to the appliance at the time of the conversion. See fig. 18.

### Derating procedure

1. Install the appropriate orifice per the High Altitude Chart.
2. Remove the burner tube to expose the main burner orifice.
3. Use a 1/2" deep well socket or open end wrench to remove the orifice and replace with the appropriate one from the high altitude adjustment kit.
4. Attach the high altitude conversion sticker provided to the rating plate on the appliance. See figure 14.
5. It may be necessary to adjust the air shutter on the burner tube. See the Flame Picture / Air Shutter Adjustment on the next page for more details.

GAS TYPE	ORIFICE SIZE	ELEVATION	JØTUL PART NO.
NATURAL GAS	#33	0 - 2000' (0 - 619m)	220641
PROPANE	#52	0 - 2000' (0 - 619m)	045025
NATURAL GAS	#34	2001' - 4500' (611 - 1170m)	224364
PROPANE	1.55 mm	2001' - 4500' (611 - 1170m)	220048

Table 1. High Altitude Orifice Chart.

<p>THIS APPLIANCE HAS BEEN CONVERTED FOR USE AT AN ALTITUDE OF _____ Orifice Size: _____ Manifold Press: _____ Input, BTU/Hr: _____ Fuel Type: _____ Date of Conversion: _____ / _____ / _____</p>
--

Figure 18. High Altitude Conversion Notice Label

## Flame Picture / Air Shutter Adjustment

THIS APPLIANCE IS SHIPPED FROM THE FACTORY EQUIPPED FOR USE WITH NATURAL GAS. IF CONVERTING TO PROPANE, IT WILL BE NECESSARY TO ADJUST THE AIR SHUTTER ON THE BURNER TUBE TO ACHIEVE THE PROPER GAS TO AIR MIX. SEE FIG. 16.

### WARNING:

**AIR SHUTTER ADJUSTMENTS SHOULD ONLY BE PERFORMED BY A QUALIFIED PROFESSIONAL SERVICE TECHNICIAN.**

The air shutter adjustment can also help achieve the desired flame appearance. Generally, flame appearance is a matter of preference, however most people enjoy a warm, yellowish flame.

**Closing the Air Shutter** - Insufficient combustion air will result in very long yellow flames that can promote soot. Sooting produces black deposits on the logs, on the inside walls of the appliance, and potentially on the exterior termination cap.

Sooting is caused by incomplete combustion in the flames and lack of combustion air entering the air shutter opening.

**Opening the air shutter** - will generate a flame that is blue and transparent, or an “anemic” flame. This flame is generally more efficient, but not very attractive.

Jøtul recommends the following settings for the Katahdin gas insert:

Propane: 3/16” open

Natural Gas: 1/16” open

Run the insert for a minimum of 15 to 20 minutes for an accurate representation of the flame appearance. This should be done before and between any air shutter adjustments.

To adjust the air shutter:

1. Loosen the air shutter stem wing nut located under the firebox. See fig. 19.
2. Sliding the stem to the right opens the shutter and increases air/fuel ratio. Sliding it to the left restricts air flow and decreases the air/fuel ratio.
3. Allow insert to burn 30 minutes on the HIGH setting, observing the flame continuously. Make further adjustments in 1/8” inch increments and let the flame settle-in before making subsequent adjustments.
4. If the flame appears weak, slow, or sooty, repeat the process described above until the flame is as desired.

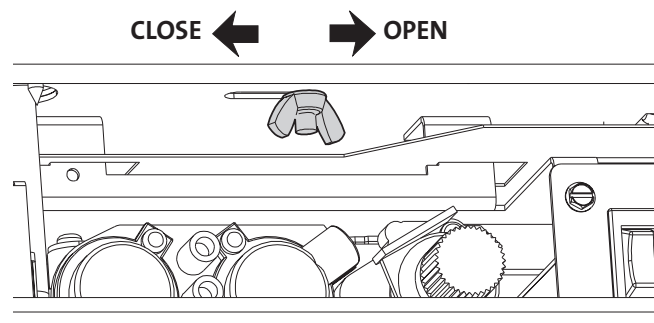

Figure 19. Air Shutter location.

# Install Optional Brick Panels

#157220 Boston Buff Beige

#157221 Chimney Red

**Kit Contents:**

- Left and Right Panels
- Upper and Lower Rear Panels
- Left and Right Corner Base Panels
- Front Base Panel

**Tools Required:**

- 1/4" nut driver
- 10 mm socket wrench

**CAUTION !**

**THE PANELS ARE EXTREMELY FRAGILE. HANDLE TENDERLY, BEING CAREFUL TO AVOID DAMAGING THE EDGES FROM CONTACT WITH OTHER PARTS OF THE FIREPLACE.**

1. Remove the two cast iron side panels from the firebox. Use a 1/4" nut driver to remove the retainer brackets located at the rear corner of each panel, as shown at right. The panels will not be reinstalled, however **YOU MUST REPLACE THE SCREWS IN THOSE LOCATIONS.** Fig. 20
2. Use the 10 mm socket wrench to remove the two Grate assembly M6 flange head hex nuts located behind the grate crossbar. Remove the Grate assembly from the firebox and set aside. Figs. 21 -22.
3. Remove the burner tube by lifting it slightly and sliding it to the right to disengage it from the ainlet shutter.
4. Set the base panels into place in the firebox, being careful to avoid chipping the edges. See fig. 23
5. Place the brick panels into position in the numerical order indicated in fig. 24.



Figure 21. Remove left side Grate assembly M6 nut...

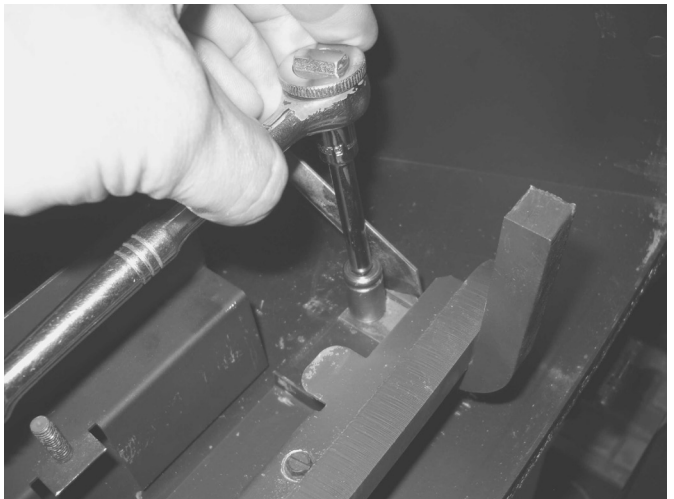

Figure 22. ... and right side Grate assembly nut.

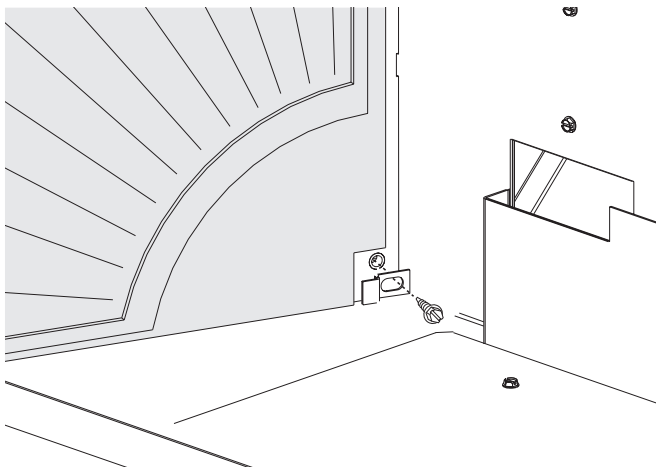

Figure 20. Ornamental cast iron panel removal. **REPLACE SCREW IN THE HOLE AFTER REMOVING BRACKET AND PANEL.**

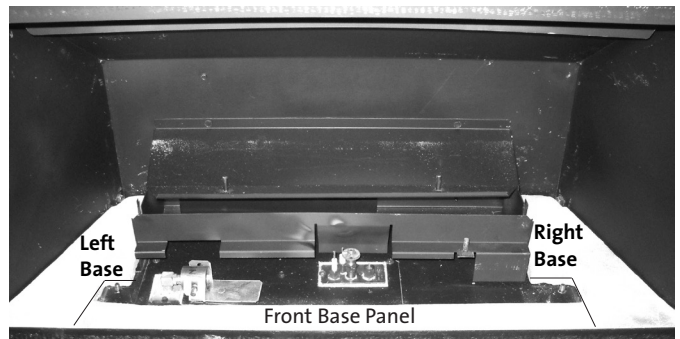

Figure 23. Base panel locations.



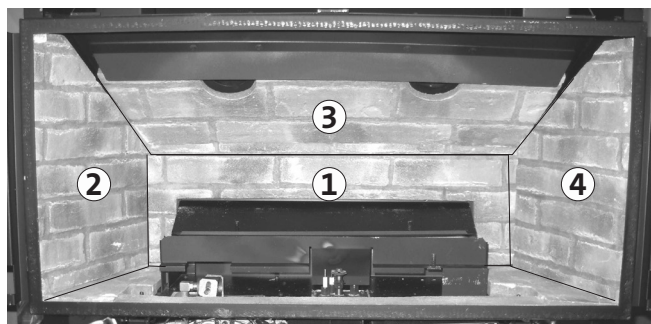

Figure 24. Install brick panels in the order indicated above.

6. Replace the Grate assembly and secure it with the nuts previously removed.
7. Replace the burner tube. Correctly installed, it will be level, with the lower half engaged within the air shutter, and the upper half seated behind the air deflector. See figs. 25 and 26.



Figure 25. Correct burner tube alignment.



Figure 26.

## Install the Log Set

NOTE: Install the optional Brick Panels before installing the Log Set.

The Katahdin is equipped with a seven-piece log set packaged separately.

1. Unwrap each log and set on floor near unit. Check for damage.
2. Install the Rear Base Log on pegs on the rear skirt. Fig. 27.



Figure 27. Rear Base Log

3. Install the Front Base Log on its pegs. Fig. 28.
4. Install the Front Left Log . Fig. 29.



Figure 28. Front Base Log



Figure 29. Front Left Log

5. Install the Front Right Log. Fig. 30.
6. Install the Upper Left Log and Upper Right Logs on the the associated pegs in the Rear Base Log. Fig. 31.
7. Install the Upper Center Log on its peg. Fig. 32.
8. Spread the Ember Stones evenly across the burner tube screen. It is best to equally space these embers for optimum flame appearance. NOTE: YOU DO NOT NEED TO USE ALL OF THE EMBER STONES. You may also wish to spread some ember stones across the front of the ceramic base panel.
9. Use tweezers to pinch small tufts of Rock Wool over the ember stones to produce an enhanced glowing effect.

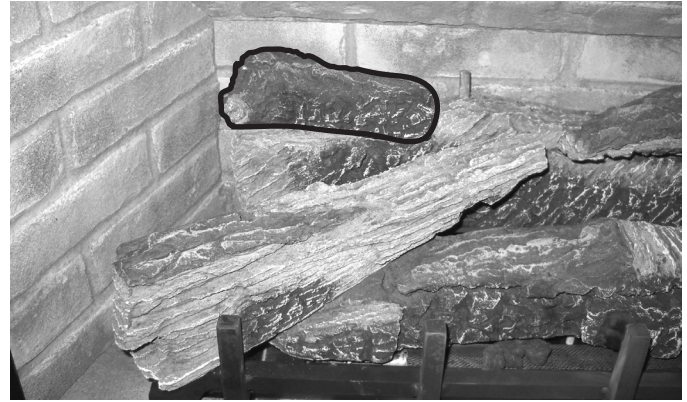

Figure 32. Upper Left Log



Figure 30. Front Right Log



Figure 33. Upper Center Log

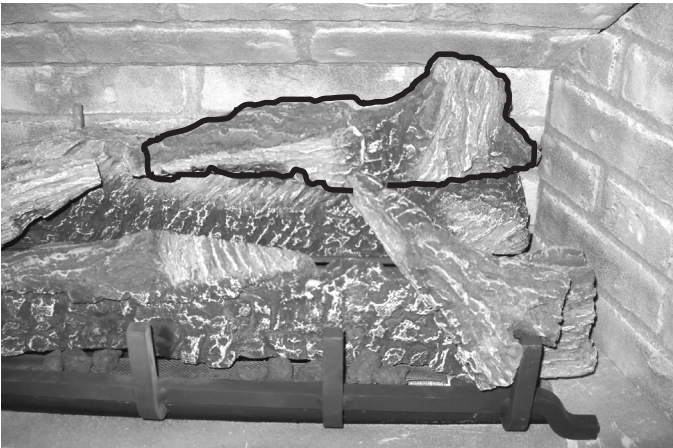

Figure 31. Upper Right Log



## Wall Thermostat

NOTE: DISCONNECT POWER TO THE UNIT BEFORE INSTALLING THE THERMOSTAT.

Use only a 750 millivolt DC two-wire circuit thermostat. The thermostat should be placed in the same room as the heater, typically 5' off the floor. Avoid drafty areas or any area that may affect the accuracy of the thermostat.

- Use a 1/4" nut driver to remove the Burner Controls face plate with removal of the two sheet metal screws.
- The thermostat or receiver leads should be connected to the open terminal block using a minimum 18 gauge wire having a maximum length of 20 feet. See fig 34.
- At the thermostat, the two wires should be connected to the two connection screws on the thermostat base plate according to the manufacturer's instructions.
- For the thermostat to function, the Burner switch must be in the STAT position. The thermostat will then control the burner function with the Pilot Mode switched to either IPI or CPI modes.

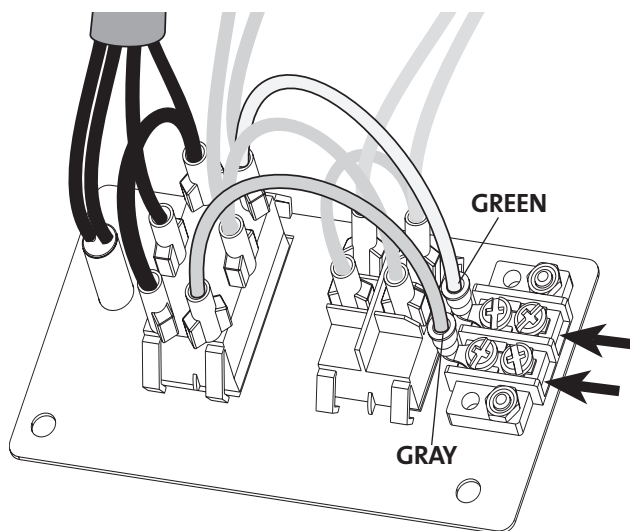

Figure 34. Wall thermostat / Remote Control connections.

## Remote Control #129706

The optional Jøtul Remote Control can be used with the GI 450 DV II TSI, however, **the receiver must be installed outside of the firebox cabinet.**

If there is no room for it within the fireplace, consider installing the receiver in a nearby wall. Use 200°C, 18 gauge wire for extension, if needed. **KEEP ALL WIRING FROM DIRECT CONTACT WITH THE BOTTOM OF THE FIREBOX.**

NOTE: DISCONNECT POWER TO THE UNIT BEFORE INSTALLING THE RECEIVER.

Remove the burner control face plate and connect the remote receiver leads to the open terminals on the back of the switch plate as shown in fig. 34.

## Cast Iron Grill Assembly

Attach the upper and lower grill halves together using the pre-installed M6 x 12 mm bolts and washers.

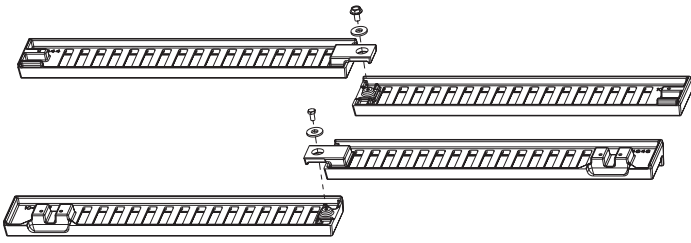

Figure 35. Upper and lower grill assembly.

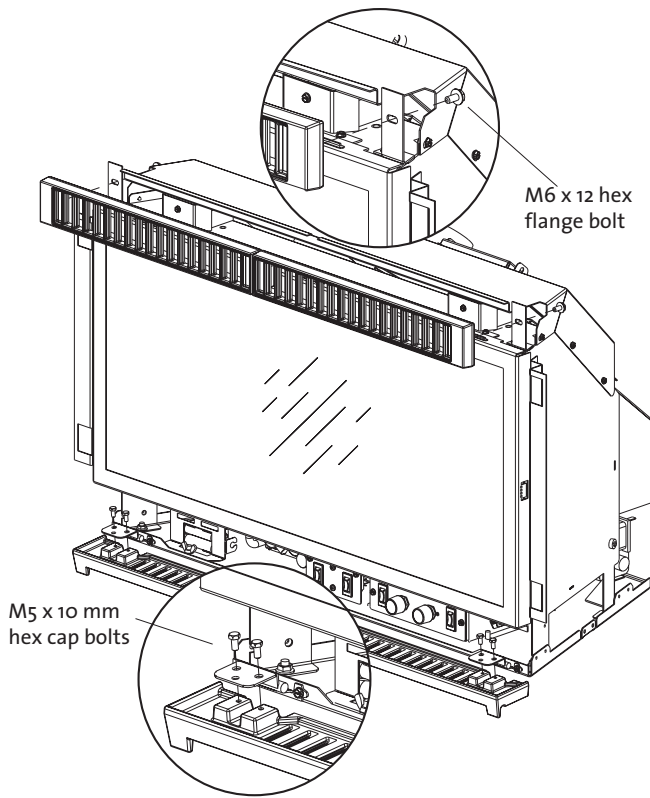

Figure 36. Installing grill assemblies onto the fireplace.

## Surround Panel Installation

All Surround Panel fasteners are already installed in the appropriate locations. Simply remove and use them to attach the panels together in the same locations. A 10 mm wrench will be required.

**RISER BAR:** The 2" riser bar is used in conjunction with the standard cast iron surround, and is only needed in the event that the fireplace opening is between 27 1/2" and 29 1/2" high. The riser bar can be used in any installation if desired. See fig. 37.

1. If the riser bar is to be used, the insert must be lifted 2" off the floor of the fireplace to allow for the riser bar to fill the space below the bottom grill assembly. See fig. 37. Install the leveling legs to achieve the appropriate height.

**NOTE:** THE COMBINED WEIGHT OF THE CAST IRON SURROUND AND RISER BAR MAY CAUSE THE UNIT TO BECOME TOP-HEAVY. IN THAT CASE, INSTALL THE STABILIZER BAR THAT IS SUPPLIED WITH THE FIREPLACE. THE STABILIZER BAR ATTACHES TO THE TOP OF THE FIREBOX AND WILL BRACE THE UNIT AGAINST THE FIREPLACE LINTEL TO PREVENT THE UNIT FROM LEANING FORWARD. See figs. 37 and 38.

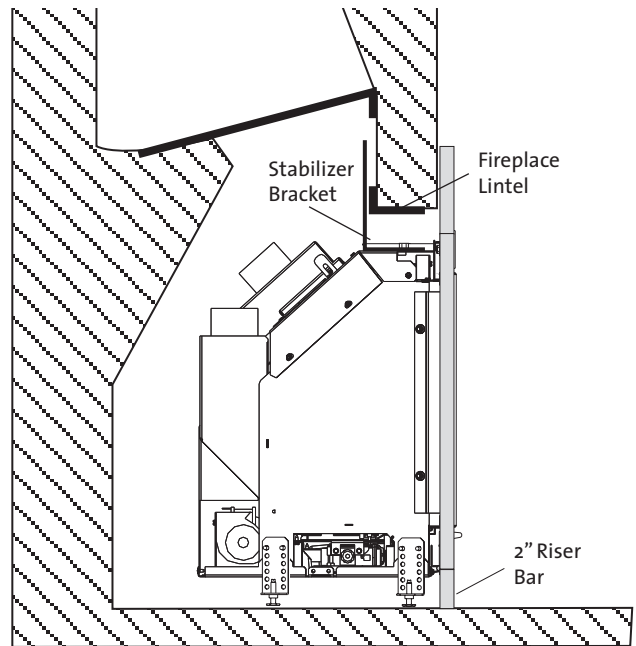

Figure 37. Installing the Stabilizer Bar.

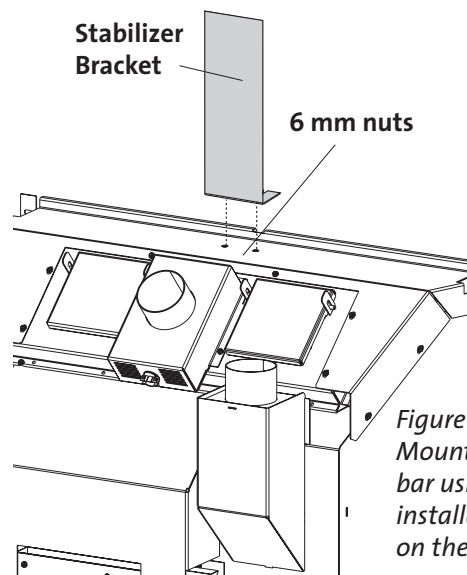

Figure 38. Mount the stabilizer bar using the two pre-installed 6 mm nuts on the top of the unit.

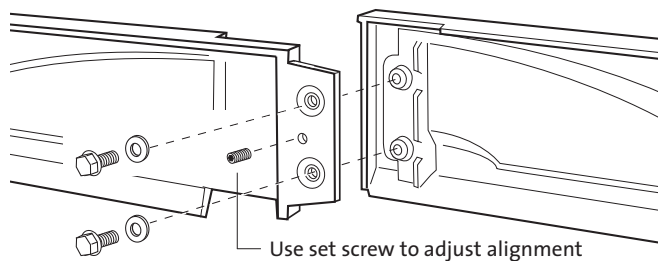

Figure 39. Attach Surround Breastplates

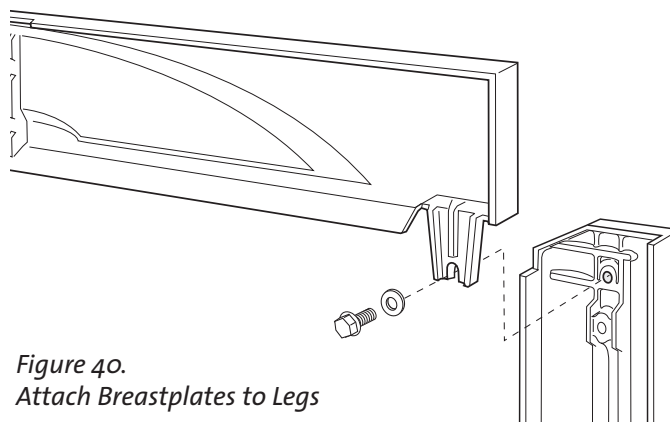

Figure 40.  
Attach Breastplates to Legs

2. Lay the four surround panels on the floor backside up. Using two bolts and washers attach the right and left upper sections (breastplates) together. See fig. 39.
- 3 Attach the left and right leg sections to the breastplate assembly using a bolt and washer on each side. See fig. 40.
4. Four mounting tabs are attached to the back of the surround panels at the factory. Be sure all four tabs are in place and secure. See fig. 41.
5. Stand the assembled surround up and gently lift to the unit. Align the mounting holes on the sides of the insert with the mounting tabs on the surround. See fig. 42.
6. Secure the two sections of the riser bar together with a washer and bolt and bolt the assembled riser bar to the surround legs as shown in fig. 43.
7. Slide the surround down into the mounting holes. Be sure all four mounting tabs engage securely with the adjacent bracket holes. See fig. 43.

Note: the riser bar is not used for support of the insert- if more space is needed for the riser bar, raise the unit using the levelling legs. See figure 37 .

8. Gently and slowly push the unit and surround back into the fireplace. This is best done by pushing the front outside edges of the glass frame. Reminder: Be sure to inspect the gas line and blower cord to make sure they are not compressed when the unit is in its final location.

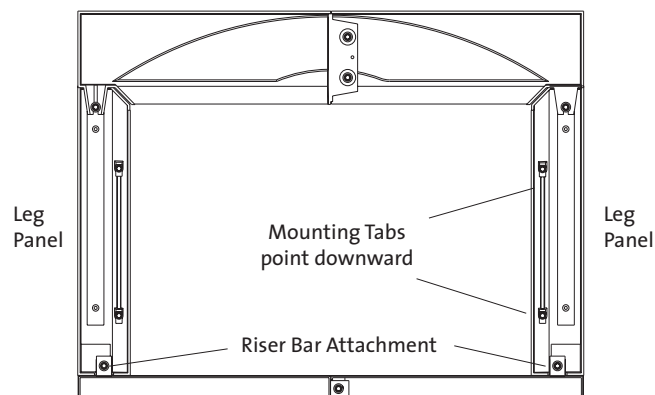

Figure 41. Surround mounting tab locations.

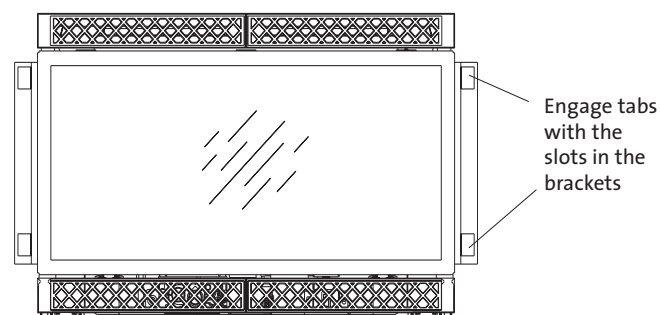

Figure 42. Surround engagement with firebox.

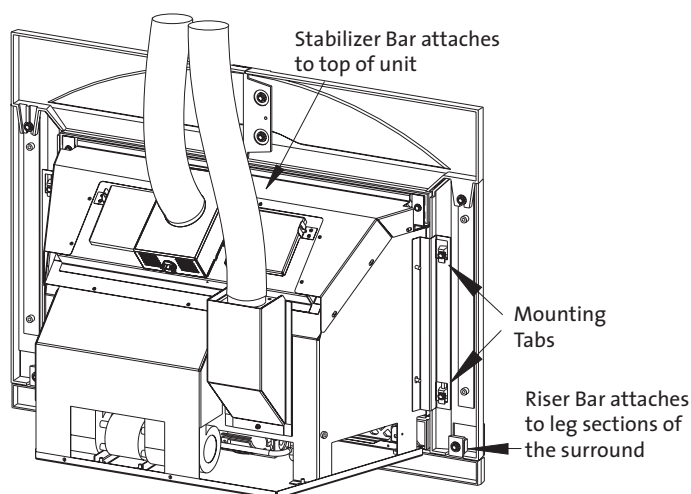

Figure 43. Riser Bar installation.

**See Appendix B, page 33, for Simple Surround and Wide Surround assembly instructions.**

# Fireplace Operation

## Burner Controls

- Burner function may be manually controlled by placing the burner switch in the ON/OFF position, fig. 44. In the ON position, the preheat light will come on indicating Draw Collar activity. Within about 2-3 minutes, the pilot will ignite followed by main burner ignition. This is the normal operating position for manual control.
- The STAT position permits automatic control through use of an optional wall thermostat or remote control device. NOTE: In this mode, the preheat lamp will continue to cycle on and off with fluctuating interior temperatures, regardless of whether or not the thermostat calls for heat.

## Pilot Modes - TruStart Ignition™ System

- **Intermittent Pilot Ignition & Draw Collar ( IPI /DC )**  
This switch should be left in IPI / DC position for normal operation. This feature turns off the pilot flame when there is no call for heat, thereby conserving fuel. Ideal for use with thermostatic or remote operation, the control activates a heat element (Draw Collar) within the firebox exhaust vent outlet. When the thermostat or remote calls for heat, the PREHEAT lamp will indicate Draw Collar warm-up. Pilot ignition occurs after approximately two to three minutes, or when the vent is sufficiently heated to induce draft followed by main burner ignition.
- **Continuous Pilot Ignition ( CPI )**  
When switched to this position, the pilot will remain burning even when there is no call for heat. Use this mode in the event of a power outage. A battery back-up permits continued burner operation whenever 110V electricity is unavailable.  
Exercise caution when operating with a continuous pilot. DO NOT USE CLEANING PRODUCTS HAVING COMBUSTIBLE VAPORS NEAR THE OPERATING FIREPLACE.

## Flame Picture

- The gas control valve regulator provides easy adjustment of flame height, appearance, and heat output. To adjust the flame between the HI and LO setting, rotate the HI/LO knob, located on the valve face.  
NO SMOKE OR SOOT SHOULD BE PRESENT. CHECK LOG PLACEMENT IF ANY SOOT OR SMOKE IS APPARENT. IF SOOT OR SMOKE PERSIST, THE AIR SHUTTER MAY REQUIRE ADJUSTMENT.

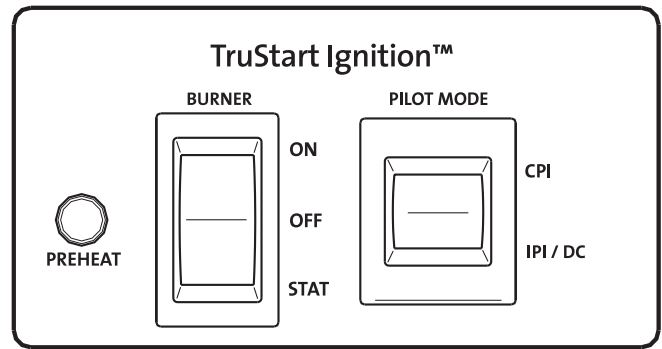

Figure 44. Burner controls.

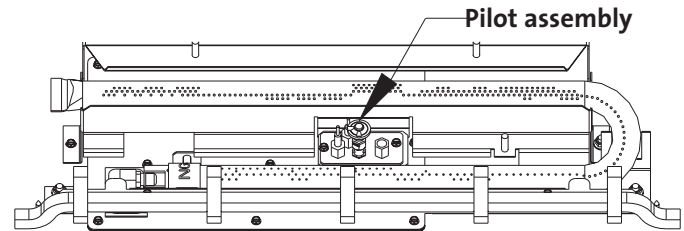

Figure 45. Pilot assembly location.

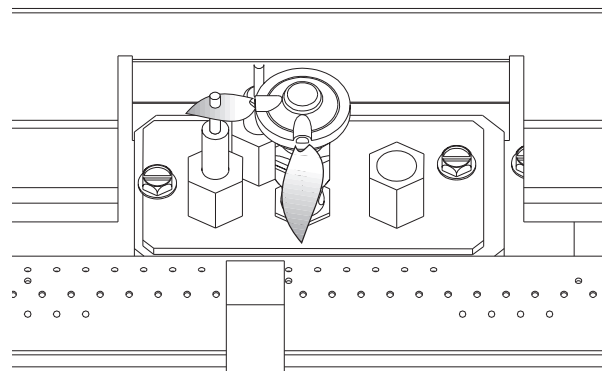

Figure 46. Correct Pilot Flame Pattern.

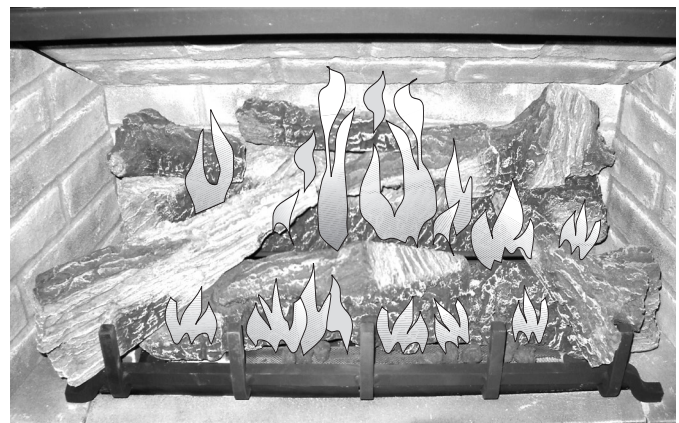

Figure 47. Correct Burner Flame Pattern.





## Blower Operation

The GI 450 DV II TSI Katahdin is equipped with a 125 cfm heat-activated blower. The power cord should be connected to the nearest 120V house current outlet.

The cord is equipped with a three-prong (grounding) plug for protection against shock hazard and should be plugged directly into a properly grounded three-prong receptacle. **DO NOT CUT OR REMOVE THE GROUNDING PRONG FROM THE PLUG.**

The blower must be electrically grounded in accordance with local codes or, in the absence of local codes, with the current NFPA 70- National Electrical Code or CSA C22.1-Canadian Code.

The blower is controlled by a heat activated switch (snapstat) that will function only if the blower control switch is in the Automatic (  ) setting. Once the firebox heats after the burner has been operating for a short time, the blower will power on regardless of speed control setting. In Automatic (  ) mode, the blower will continue to operate after the burner is turned off, until the snapstat cools. See fig. 48.

In the manual power ON (  ) position, the blower will function regardless of the temperature of the fireplace.

If blower operation is not desired, place the control switch in the OFF (  ) position to bypass the snapstat function.

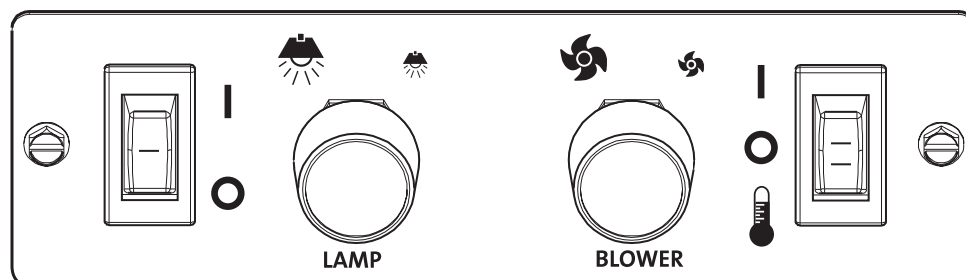

Figure 48. Blower and Accent Lamp Controls

## Accent Lamps

Twin accent lamps are controlled by the switch and dimmer located to the left of the blower controls.

Use of the accent lamps will assist in maintaining draft in very long vent runs and thereby help ensure consistent IPI performance.

### CAUTION:

**ALWAYS DISCONNECT ELECTRICAL POWER WHEN SERVICING THIS APPLIANCE.**

**LABEL ALL WIRES PRIOR TO DISCONNECTION WHEN SERVICING THE CONTROLS. WIRING ERRORS CAN CAUSE IMPROPER AND DANGEROUS OPERATION. ALWAYS VERIFY PROPER OPERATION AFTER SERVICING THE APPLIANCE.**

### ATTENTION:

**AU MOMENT DE L'ENTRETIENDES COMMANDES, ETIQUETEZ TOUS LES FILS AVANT LE DEBRANCHEMENT. DES ERREURS DE CABLAGE PEUVENT ENTRAÎNER UN FONCTIONNEMENT INADEQUAT ET DAGEREUX.**

## System Check

- **Initial System Purge:** When lighting the appliance for the first time, or after a long period of disuse, it will take a few moments to clear the gas line of air. Once this purge is complete, the appliance will operate as described in the lighting instructions located on the insert's rating plate and back cover of this manual.
- The pilot flame should be steady - not lifting or floating. The flame should be blue in color around the pilot hood, with traces of yellow toward the outer edges. It is important that the pilot flame engulf the top 1/8" of the flame rectifier / sensor. The pilot flame should project out of the pilot hood 1" from both ports. See Figure 28.
- When lit for the first time, the fireplace will emit an odor for an hour or two. This odor is the result of burn-off of manufacturing by-products. Opening a nearby window to provide fresh air will alleviate this temporary condition.
- Condensation may occur on the glass upon each lighting of the appliance. This "fog" will disappear as the appliance temperature increases.
- Keep the controls and the area under the appliance free of debris; vacuum this area frequently. Always keep the appliance area clear and free from combustible materials, gasoline and other flammable liquids. ALWAYS be sure the insert is cold and NO hot embers or sparks are present before using a vacuum cleaner.
- **CAUTION: DO NOT OPERATE THIS APPLIANCE WITH THE GLASS REMOVED, CRACKED OR BROKEN.**

**CAUTION:**

**THE IGNITION SYSTEM OF THIS APPLIANCE CARRIES LIVE VOLTAGE. ALWAYS TURN OFF THE GAS SUPPLY TO THE INSERT AND DISCONNECT THE POWER SOURCE BEFORE ANY SERVICE WORK IS PERFORMED, INCLUDING BATTERY REPLACEMENT.**

## Maintenance

This appliance and venting system should be inspected before use and at least annually by a qualified service technician

### General cleaning:

Vacuum the controls area under the firebox at least monthly or more frequently if pet hair is in the environment.

The firebox should be vacuumed annually. Be sure to vacuum or wipe off the pilot assembly and burner orifice and burner tube. Use a brush attachment to vacuum the log set.

Inspect the pilot assembly for signs of corrosion and replace any suspect components.

**Gasket inspection:** Inspect the glass gasket annually. Examine the gasket for signs of deterioration or stiffness and confirm that the gasket maintains a positive seal. This is important to prevent combustion gases escaping into the room. Replace the gasket if necessary. Refer to the replacement parts list on page 31.

## Accent Lamp Replacement

1. Remove the cast iron Upper Grill
2. Remove the lamp shade and bulb receptacle (three screws). See fig. 54, pg. 31. Replace with 222943 130V, 50W light bulb.
3. Handle the new bulb with gloves. Skin oils will cause the bulb to fail prematurely. If you touch the bulb with your bare skin, wipe it clean with a soft cloth.
4. Replace components previously removed.

## Battery Replacement

Loosen the battery box wing nut and pull the box out of the insert. Bend the retainer bracket out of the way. Replace with four AA batteries noting polarity indicated on the holder.

## Glass Care

Moisture condensation is a normal occurrence with gas appliances and particulate accumulation may appear on the inside surface to the glass. Use a dampened, soft cloth to clean the glass and polish with a dry, soft towel. Specially-formulated ceramic glass cleaner may also be used. **DO NOT USE ABRASIVE OR AMMONIA BASED CLEANING SOLUTIONS. TAKE CARE NOT TO SCRATCH THE GLASS SURFACE.**

## Glass Replacement

### To remove the glass panel or glass gasket:

1. Open the Controls Panel. Loosen battery box wing nut and push the box out of the way of the latch mechanism. See fig. 13, pg. 16.
2. Use the Latch Tool to release the glass clips on either side of the bottom of the firebox.
3. Swing the bottom of the glass frame out and lift up to disengage it from the firebox.
4. Lay the assembly on a flat surface and use a flat blade screwdriver or pliers to pry up the two steel tabs that secure the glass panel to the frame.
5. Install the new glass panel and gasket in the glass frame and secure with the steel tabs. Do not over tighten the tabs as that could break the glass.

**ALWAYS USE JØTUL AUTHORIZED PARTS. NEVER SUBSTITUTE ANY OTHER PARTS.**

**WARNING:**

**OBSERVE CAUTION NEAR THE GLASS. THE GLASS PANEL MAY SHATTER IF STRUCK WITH AN OBJECT. ALWAYS HANDLE THE GLASS PANEL WITH CARE.**

**REPLACEMENT OF THE GLASS SHOULD BE DONE BY A LICENSED OR QUALIFIED SERVICE PERSON. USE ONLY REPLACEMENT GLASS PROVIDED BY YOUR AUTHORIZED JØTUL DEALER. NEVER SUBSTITUTE ANY OTHER COMPONENTS.**

With proper care and maintenance, your appliance will provide you with years of enjoyment. If you experience any problem with your Jøtul GI 450 DV II TSI Katahdin gas insert, contact your Jøtul Authorized Dealer for assistance.

**RETAIN THIS MANUAL FOR REFERENCE AND MAKE IT AVAILABLE TO ANYONE USING OR SERVICING THE INSERT.**

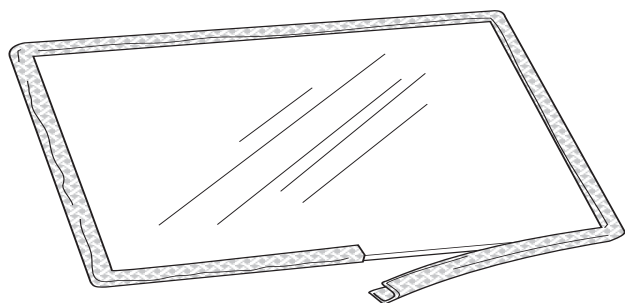

*Figure 49. Gasket application, PN 129124.*

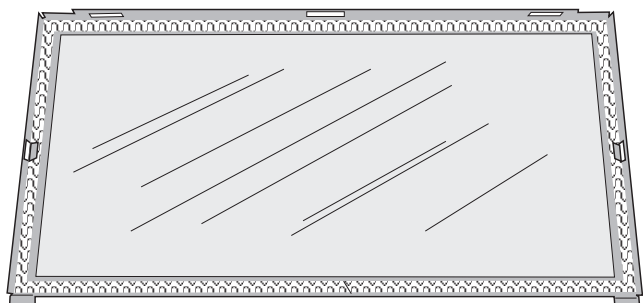

*Figure 50. Glass Replacement. Bend tabs to secure panel.*

# Jøtul GI 450 DV II TSI Replacement Parts

**ONLY USE  
REPLACEMENT PARTS  
PROVIDED BY AN  
AUTHORIZED  
JØTUL DEALER.**

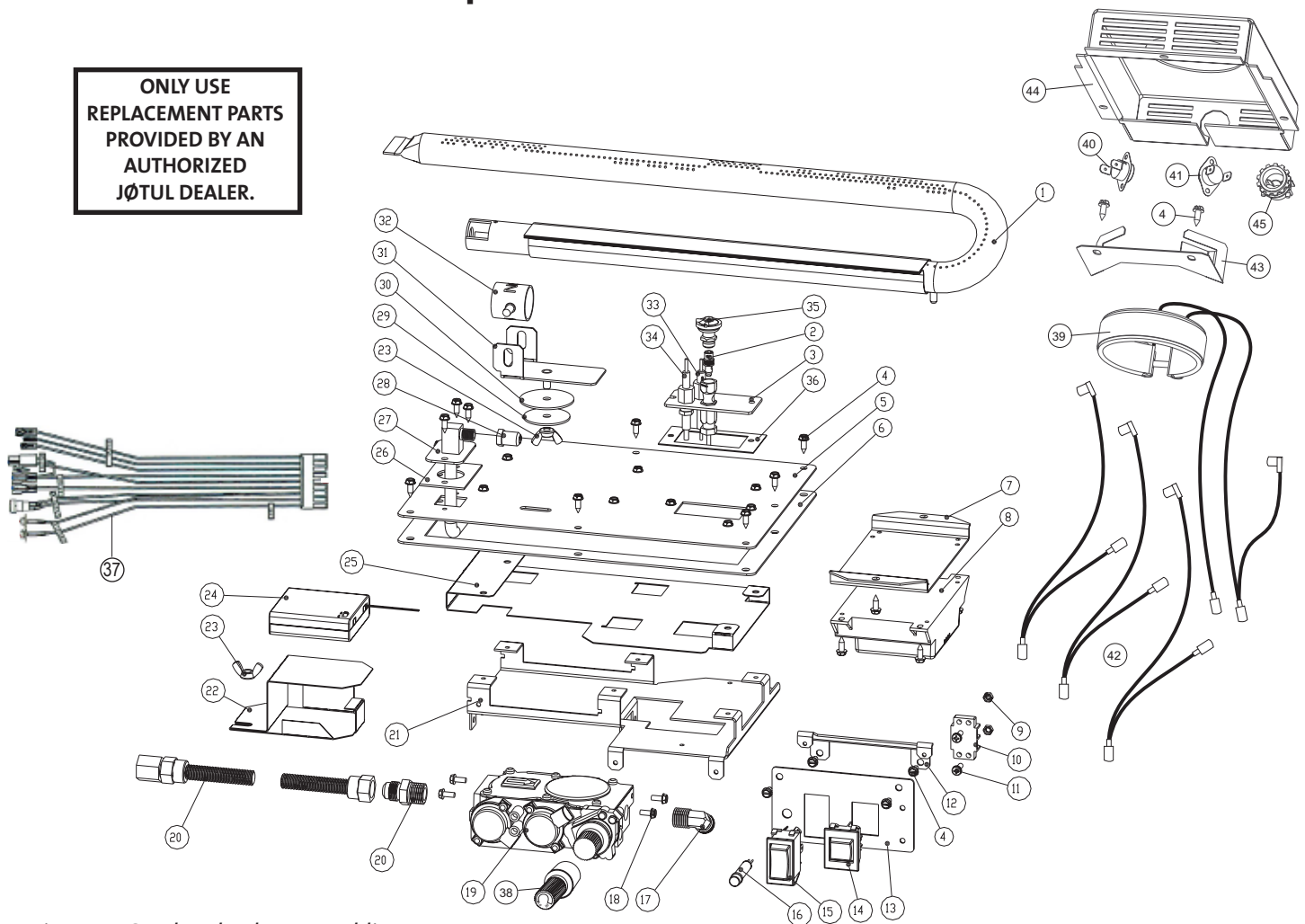
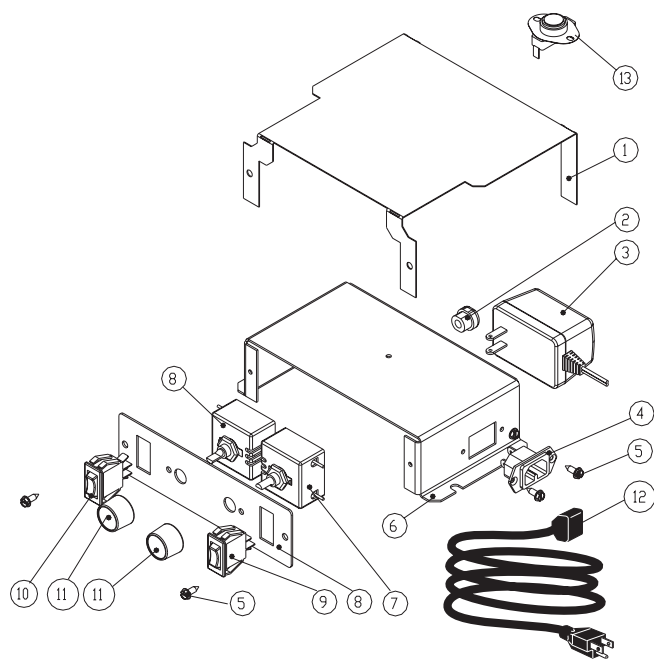

Figure 51. Spud and Valve Assemblies

No.	Part Number	Description
1	154994	Burner Tube, GI 450 DV II
2-32	157266	Spud Assembly, Complete - GI 450 DV II TruStart
2	129472	Orifice, Pilot - #51 (NG, Pop-Top)
	222057	Orifice, Pilot - #35 (LP)
3	222925	Proflame Pilot, NG
4	117917	Screw, HWH SMA 8 x 1/2 SL Blk Oxide
5	22395292	Spud Cover Plate, Matte Black
6	129669	Gasket, Spud Plate Assembly
7	223244	Bracket, IPI Ignition Board
8	222924	Proflame IPI Ignition Board
9	117922	Nut, Hex M4 DIN 934 PLAIN
10	129154	Terminal Block, 2 Pole 77 series
11	117912	Screw, Pan Hd Ph M4 x 12 Blk Ox
12	224492	Bracket, Extension Faceplate, GI450 DVII - TSI
13	224498	Faceplate, SScreened - TSI
14	224496	Switch, Rocker, DPST, Black, Plain
15	224490	Switch, Rocker, DPDT, Black, Plain
16	224495	Indicator Light, 120V Amber, Neon
17	222292	Elbow, 90°, Brass 3/8 NTP X 3/8" Dia Tube
18	118214	Screw, #8 X 1/4", Taptite, SLHWH, SZPL
19	223980	Proflame Valve, Manual Hi/Lo, NG
20	129707	Flex tube w/connectors (3/8" O.D. x 24")
21	223953	Valve Bracket

No.	Part Number	Description
22	22410792	Heat Shield, Battery
23	117975	Wing Nut, M6 Zinc
24	224262	Battery Holder w/ cover - 4AA
25	223901	Heat Shield, Valve
26	222280	Gasket, Drop In Orifice Holder
27	223231	Orifice Holder, Drop In Assembly, 12.5 in. tube
28	220641	Orifice, #33 - NG
	045025	Orifice, #52 - LP
29	118029	Washer, Fender .250 x 1.500 dia.
30	221107	Gasket, Primary Air Shutter
31	224104	Handle, Air Shutter, Internal, GI 450 DVII
32	221390	Primary Air Shutter Assembly
33	224347	Spark Electrode & Cable, Proflame Pilot
34	224348	Sensing Electrode & Cable, Proflame Pilot
35	224349	Pilot Hood, 2 Flames, Proflame Pilot
36	129670	Gasket, Pilot Assy
37	157264	Wire Harness, SIT Proflame DFC
38	129730	Regulator Knob Extension
39	157436	Band Heater Assembly (Draw Collar)
40	224886	TSI AC Snapstat (NC)
41	224887	TSI Control Snapstat (NO)
42	157437	TSI Wire Harness
43	224478	Snapstat Bracket
44	15	Draw Collar Cover
45	117981	Strain Relief, Steel

Figure 52. Dimmer & Blower Controls Assembly



No.	Part Number	Description
1	224103	Heat Shield, AC Controls
1,2,4-11	157438	Control Assembly, Complete - GI 450 DVII TSI
2	117981	Wire strain relief - Non-metallic cable
3	223982	AC/DC Adapter, High Temp, 7V
4	221790	Receptacle, High Temperature
5	117917	Screw, HWH SMA 8 x 1/2 SL Blk Oxide
6	224102	Control Box, Receptacle
7	220970	Rheostat, Long Lead - 26in
8	224101	Face Plate, Blower / Light, GI 450 DVII, Silk Screened
9	220703	Switch, Rocker, SPDT, Center Off, Black, Plain
10	120517	Switch, Rocker, SPST, Black, Plain
11	220709	Knob, Rheostat Control, 1" Dia.
12	222093	Power Cable
13	220637	Snapstat

Figure 53. Blower Assembly

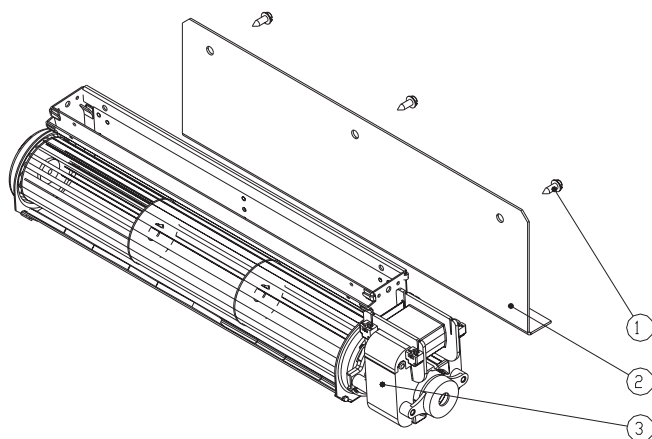

No.	Part Number	Description
1	117917	Screw, HWH SMA 8 x 1/2 SL Blk Oxide
2	222799	Blower Bracket, GI 450
3	222072	Blower, TransFlow, 12" Cage, 120 CFM

Figure 54. Lamp Assembly

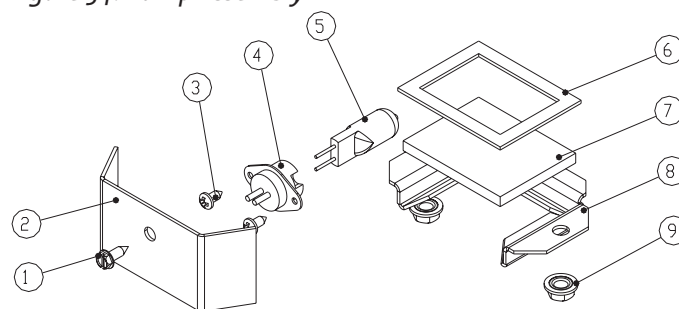

No.	Part Number	Description
1	117917	Screw, HWH SMA 8 x 1/2 SL Blk Oxide
2	22397092	Light Shade, Matte Black
3	118015	Screw, PH SMA #7x1/2 Zinc
4	157323	Light Fixture, High Temperature
5	222943	Light Bulb, 130 Volt, 50 Watt
6	222977	Gasket, Light Kit
7	222974	Glass, Ceramic, Light Fixture
8	22297592	Glass Retainer, Light Fixture - Matte Black
9	117968	Nut, M6 Serrated Flange plain

Figure 55. Glass Assembly

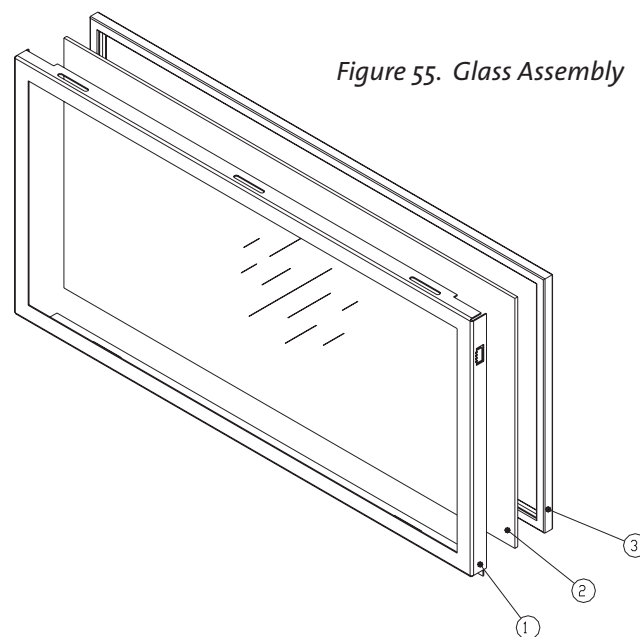

No.	Part Number	Description
1	12961792	Glass Frame, Matte Black
2	154986	Glass Panel w/ gasket
3	129124	Gasket, Fiber Glass w/ Graphite, .25 X 1.38 Nominal



# Appendix A

## Wiring Diagram

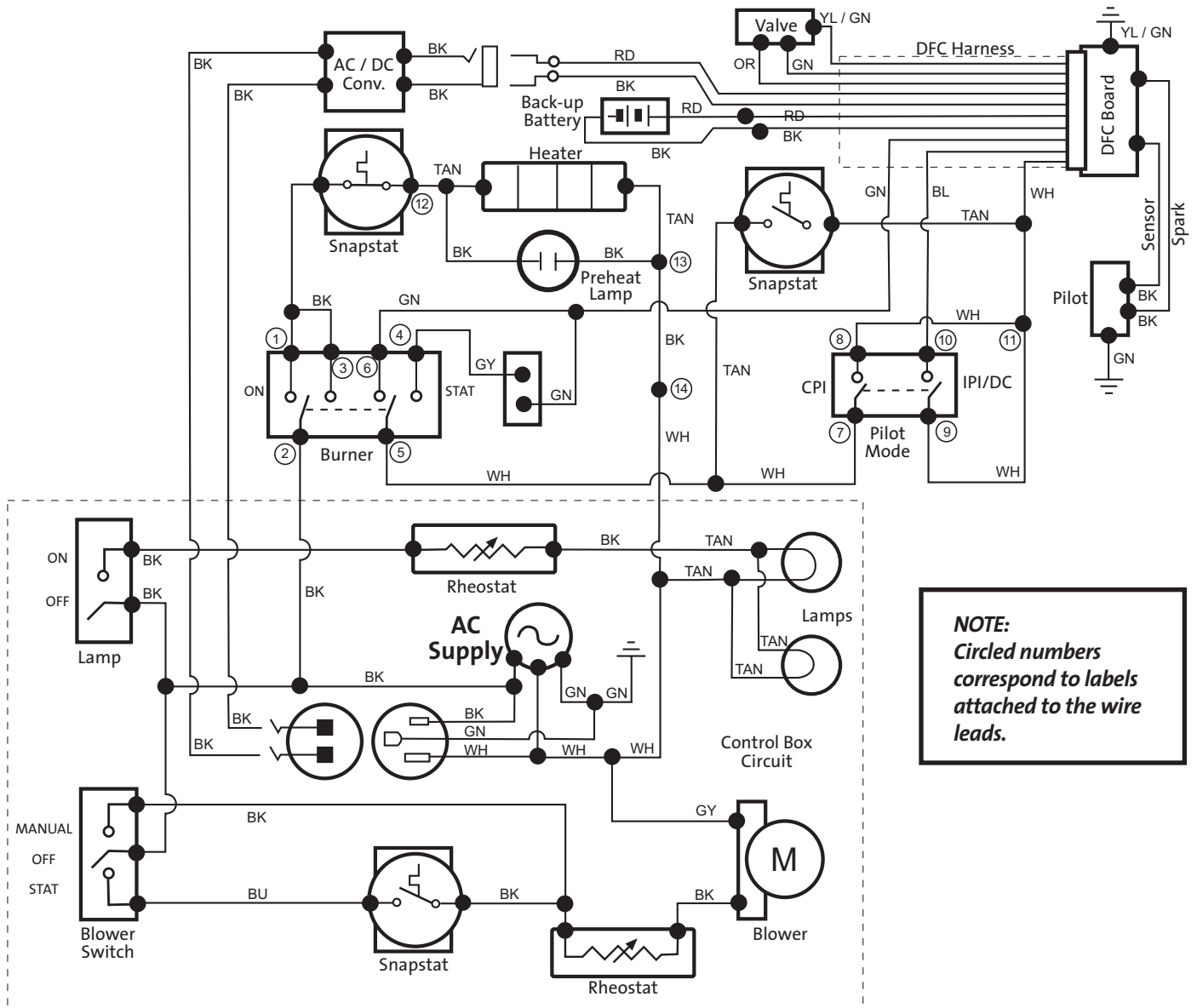

Figure 56. Jøtul GI 450 DV II TSI System wiring diagram.

# Appendix B

## Steel Grill and Simple Surround Assembly

### Tools Required

- 1/4" socket driver or spade screwdriver
- 10 mm socket or open end wrench
- safety glasses and gloves

### Procedure

1. Install the Upper Grill using 2, m6 x 12 hex bolts supplied.
2. Attach the Lower Grill to the hinge brackets at the front lip of the insert base using a single #8 x 1/2" sheet metal screw at each end.
3. Hand bend and install the two sheet metal heat deflectors at the upper corners of the fireplace sides using the pre-installed #8 x 1/2" sheet metal screws found at those locations.
4. The plinth panel may be removed if appropriate to the installation.
5. Engage the long hanger lip of the surround panel over the top of the upper grill on the firebox face.
6. Engage the hang tabs on the surround panel legs with the slots in the support brackets.

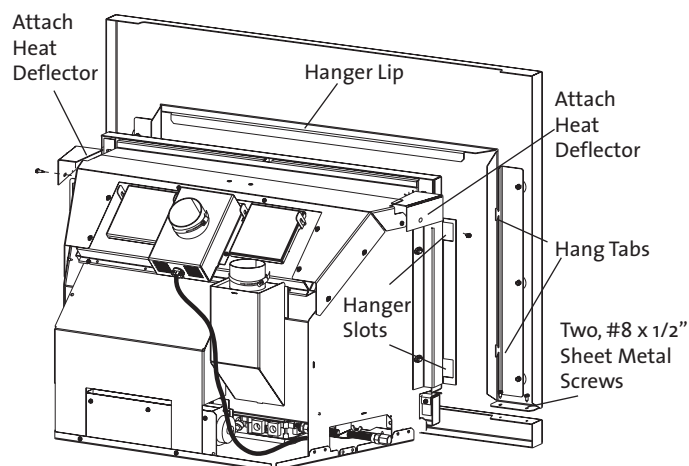
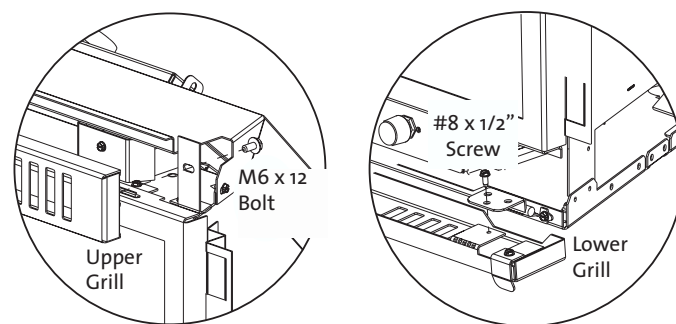

Figure 57. Steel Grill and Simple Surround installation.

## Wide Surround Assembly

*for use only with cast iron surround panels.*

### Tools Required

- 10 mm socket or open end wrench
- safety glasses and gloves
- disk grinder and metal file - if surround riser bar is not installed.

### Procedure

**If the insert is installed without the riser bar option, you must trim off the bottom 2 inches of each leg. Starting at the small precut slot, use a straight edge to draw a guideline across the leg. Use a disk grinder to cut off the excess material and file any burrs from the raw edge.**

1. Position the fireplace insert with assembled cast iron surround a few inches out from the fireplace.
2. Remove two M6 x 10 mm hex bolts already in place from each side of cast iron fireplace insert surround panels.
3. Orient the steel panel with the painted surface facing out. Lift the panel over the insert assembly and align its slots with the adjacent cast iron bolt holes. *Take care to avoid scratching the painted panel surface.*
4. Re-install the hex bolts to secure the panel to the back of the cast iron surround.
5. Push the entire insert into its final position with the fireplace.

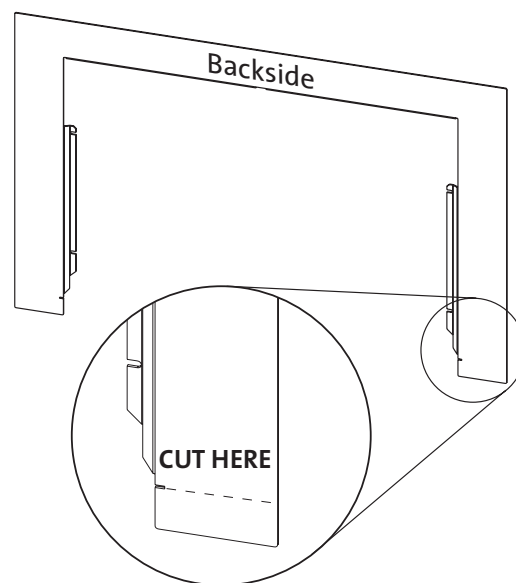

Figure 58. Simple Surround installation.

# Jøtul Gas Product Limited Warranty

This warranty policy applies to gas products identified by Jøtul, Scan, and Atra trade names, as set forth below.

## A. Cast Iron, Steel Doors, Surround Components, Firebox:

Jøtul North America Inc. (JØTUL) warrants, to the original retail purchaser, that those components of the Jøtul, Scan, or Atra Gas Stove or Fireplace specified above will be free of defects in material and workmanship for a period of five (5) years from the date of purchase. This warranty is subject to the terms, exclusions and limitations set forth in the following text.

## B. Burner, Burner Treatments, Firebox Panels:

JØTUL warrants, to the original retail purchaser, that those components of the Jøtul, Scan, or Atra Gas Stove or Fireplace specified above will be free of defects in material and workmanship for a period of two (2) years from the date of purchase. This warranty is subject to the terms, exclusions, and limitations set forth in the following text

## C. Gas & Electrical Components (controls, plumbing, valve, blower):

JØTUL warrants, to the original retail purchaser, that those components of the Jøtul, Scan, or Atra Gas Stove or Fireplace specified above will be free of defects in material and workmanship for a period of one (1) year from the date of purchase. This warranty is subject to the terms, exclusions, and limitations set forth in the following text.

JØTUL will repair or replace (including parts & labor), at its option, any of the above components determined by JØTUL to be covered by this warranty. You must, at your own expense, arrange to deliver or ship the component to an authorized Jøtul, Scan, or Atra dealer and arrange for pickup or delivery of the component after repairs have been made. If, upon inspection, JØTUL determines that the component is covered by this warranty, the repair or replacement will be made as set forth above. This warranty is not transferable and is extended only to, and is solely for the benefit of, the original retail purchaser of the Jøtul, Scan, or Atra Gas Stove or Fireplace. This paragraph sets forth the sole remedy available under this warranty in the event of any defect in the Jøtul, Scan, or Atra Gas Stove or Fireplace.

The warranty period for any replaced component will be the remaining unexpired portion of the warranty period for the original component.

Please retain your dated sales receipt in your records as proof of purchase.

## EXCLUSIONS AND LIMITATIONS

**NOTICE:** This warranty is void if installation or service is performed by someone other than an authorized installer, service agency or gas supplier, or if installation is not in conformance with the installation and operating instructions contained in this owner's manual or local and/or national fire and building regulations. A listing of local authorized installers, service agencies and gas suppliers can be obtained from the National Fireplace Institute at <http://www.nficertified.org/>.

This warranty does not cover the following:

1) Repair or replacement of parts that are subject to normal wear and tear during the warranty period or to parts that may require replacement in connection with normal maintenance. These parts include gaskets and glass (except to the extent such parts suffer damage from thermal stress).

2) Damage due to incorrect installations not in conformance with the installation instructions contained in this owner's manual or local and/or national fire and building regulations.

3) Damage due to service performed by an installer, service agency or gas supplier, unless otherwise agreed to in writing by JØTUL.

4) Labor or other costs associated with the repair of gas controls, plumbing, burners, log set, or sheet metal firebox beyond the warranty period.

5) Damage caused by unauthorized modification, use or repair.

6) Damage to enameled surfaces caused by improper operation or misuse, including use that is not in conformance with the operating instructions contained in this owner's manual. Such damage can typically be identified by bubbling, cracking, or discoloration of the enamel finish.

7) Costs incurred by travel time and/or loss of service.

8) Damage incurred while the Jøtul, Scan, or Atra Gas Stove or Fireplace is in transit.

IN NO EVENT SHALL JØTUL, ITS PARENT COMPANY, SHAREHOLDERS, AFFILIATES, OFFICERS, EMPLOYEES, AGENTS OR REPRESENTATIVES BE LIABLE OR RESPONSIBLE TO YOU FOR ANY SPECIAL, INDIRECT, INCIDENTAL, CONSEQUENTIAL, PUNITIVE OR OTHER SIMILAR DAMAGES, INCLUDING, BUT NOT LIMITED TO, LOST PROFITS, LOST SALES, INJURY TO PERSON OR PROPERTY, OR DAMAGES TO A STRUCTURE OR ITS CONTENTS, ARISING UNDER ANY THEORY OF LAW WHATSOEVER. ALL IMPLIED WARRANTIES, INCLUDING THE IMPLIED WARRANTIES OF MERCHANTABILITY AND FITNESS FOR A PARTICULAR PURPOSE, OR OTHERWISE, ARE LIMITED IN DURATION TO THE LENGTH OF THIS WRITTEN WARRANTY. EXCEPT AS EXPRESSLY SET FORTH HEREIN, JØTUL MAKES NO ORAL, WRITTEN OR OTHER WARRANTY WITH RESPECT TO JØTUL, SCAN OR ATRA GAS STOVES OR FIREPLACES.

Some states do not allow the exclusion or limitation of incidental or consequential damages, or limitations on the length of implied warranties. Therefore, the above exclusions or limitations may not apply to you. This warranty gives you specific legal rights, and you may have other rights, which vary from state to state.

JØTUL reserves the right to discontinue, modify or change the materials used to produce the Jøtul, Scan, or Atra Gas Stove or Fireplace. JØTUL shall have the right to replace any defective component with substitute components determined by JØTUL to be of substantially equal quality and price.

The dollar value of JØTUL's liability for breach of this warranty shall be limited exclusively to the cost of furnishing a replacement component. JØTUL shall not in any event be liable for the cost of labor expended by others in connection with any defective component. Any costs or expenses beyond those expressly assumed by JØTUL under the terms of this warranty shall be the sole responsibility of the owner(s) of the Jøtul, Scan, or Atra Gas Stove or Fireplace.

No dealer, distributor, or other person is authorized to modify, augment, or extend this limited warranty on behalf of JØTUL. NO MODIFICATION OR CHANGE TO THIS WARRANTY WILL BE EFFECTIVE UNLESS IT IS MADE IN A WRITTEN DOCUMENT MANUALLY SIGNED BY AN AUTHORIZED OFFICER OF JØTUL.

An authorized installer may have been provided with certain information related particularly to the Jøtul, Scan, or Atra Gas Stove or Fireplace; however, no authorized installer or other person who may service the appliance is an agent of JØTUL. No inference should be made that JØTUL has tested, certified, or otherwise pronounced any person as qualified to install or service the appliance. JØTUL shall not be liable or otherwise responsible for any error or omission by a person installing or servicing a Jøtul, Scan, or Atra Gas Stove or Fireplace.

If you believe your Jøtul, Scan, or Atra Gas Stove or Fireplace is defective, you should contact your nearest authorized Jøtul, Scan, or Atra dealer, who will process a warranty claim. IN ORDER TO QUALIFY FOR WARRANTY COVERAGE, JØTUL MUST RECEIVE NOTICE OF A POSSIBLE DEFECT WITHIN SIXTY (60) DAYS OF THE DATE THE DEFECT IS FIRST DISCOVERED, OR REASONABLY COULD HAVE BEEN DISCOVERED.

This warranty is given by Jøtul North America, Inc.,  
55 Hutcherson Drive, Gorham, Maine 04038 USA

## LIGHTING INSTRUCTIONS

### FOR YOUR SAFETY, READ BEFORE LIGHTING.

**WARNING:**  
**IF YOU DO NOT FOLLOW THESE INSTRUCTIONS EXACTLY, A FIRE OR EXPLOSION  
 MAY RESULT CAUSING PROPERTY DAMAGE, PERSONAL INJURY, OR LOSS OF LIFE.**

- A. This appliance is equipped with an ignition device which automatically lights the pilot. Do not try to light the pilot by hand.
- B. BEFORE LIGHTING, smell all around the appliance area for gas. Be sure to smell next to the floor because some gas is heavier than air and will settle to the floor.
- WHAT TO DO IF YOU SMELL GAS:
- Extinguish any open flame.
  - Open windows.
  - Do not light any appliance.
  - Do not touch any electrical switches.
  - Do not use any phone in your building.
  - Immediately call your gas supplier from a neighbor's phone.
  - If your gas supplier cannot be reached, call the fire department.
- C. Use only your hand to turn the gas control knob. Never use tools. If the knob will not turn by hand, do not try to repair it. Call a qualified technician. Force or attempted repair may result in a fire or explosion.
- D. Do not use this appliance if any part has been under water. Immediately call a qualified service technician to inspect the appliance and to replace any part of the control system and any gas control which has been under water.

## LIGHTING INSTRUCTIONS

1. STOP! Read the safety information above.
2. Set the thermostat to the lowest setting.
3. Set the Burner Control Switch to the "OFF" position.

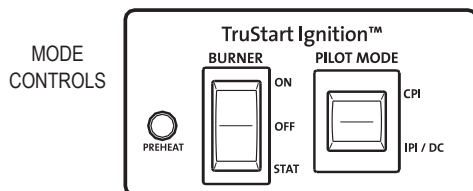

4. Set the Pilot Mode switch to the IPI / DC position for intermittent pilot and draw collar functionality. See Operation Manual for details.

Set the Pilot Mode switch to CPI for continuous pilot functionality. Use this mode in the event of a power outage.

5. This appliance is equipped with an ignition device which automatically lights the pilot. DO NOT try to light the pilot by hand.

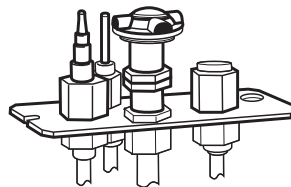

PILOT LIGHT  
ASSEMBLY

6. Wait five (5) minutes to clear out any gas. Then, smell for gas, including near the floor. If you smell gas, STOP! Follow "B" in the safety information above on this label. If you do not smell gas, go to the next step.
7. Set the Burner Control Switch to the "ON" position. In IPI mode, the pilot will light after the flue has been pre-heated by the draw collar - about 2 or 3 minutes.
8. Set the Burner Control Switch to the "STAT" position for thermostatic control.
9. Set the thermostat to the desired setting to light the burner.

If the appliance does not operate, follow the instructions "To Turn Off Gas To Appliance", and call your service technician or gas supplier.

## TO TURN OFF GAS TO THE APPLIANCE:

1. Set the thermostat to the lowest setting.
2. Turn off all electric power to the appliance if service is to be performed.
3. Set the Burner Control Switch to the "OFF" position.
4. Close control access door.

**CAUTION:** Do not operate this appliance with the glass removed, cracked or broken. Replacement of the glass panel shall be done by a licensed or qualified serviceperson.

**CAUTIONNER:** Ne pas utiliser l'appareil si le panneau frontal en verre n'est pas en place, est craqué ou brisé. Confiez le remplacement du panneau à un technicien agréé.

January 2012  
139470\_A

This appliance must be installed in conformance with local and national building regulations. Before beginning the installation, it is important that these instructions be carefully read and understood. Jøtul maintains a policy of continual product development. Consequently, products may differ in specification, color or type of accessories from those illustrated or described in various publications.

Jøtul vise sans cesse à améliorer ses produits. C'est pourquoi, il se réserve le droit de modifier les spécifications, couleurs et équipement sans avis préalable.



**Jøtul ASA**  
P.O. Box 1411  
N-1602 Fredrikstad  
Norway

**Jøtul North America**  
55 Hutcherson Drive  
Gorham, Maine 04038-2534